

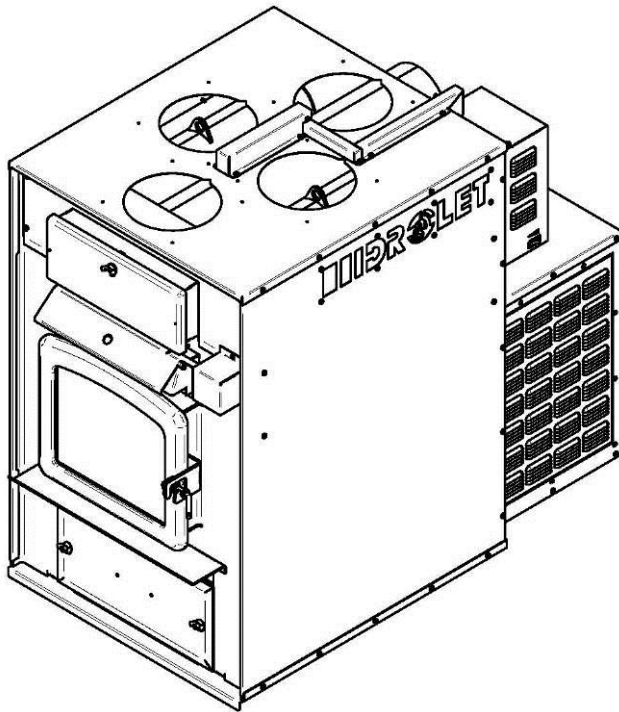

Installation and operating instructions for the **TUNDRA WOOD FURNACE** (DF02005 model)



www.kfenergy.cz

výrobce: Stove Builder International Inc.
250, rue de Copenhagen, St-Augustin-de-Desmaures
(Quebec) Kanada G3A 2H3

Výhradní distributor: KF group s.r.o., Otín 7,
Jindřichův Hradec



This manual is available for free download on the manufacturer's web site. It is a copyrighted document. Re-sale is strictly prohibited. The manufacturer may update this manual from time to time and cannot be responsible for problems, injuries, or damages arising out of the use of information contained in any manual obtained from unauthorized sources.

**READ THESE INSTRUCTIONS CAREFULLY BEFORE INSTALLING AND
OPERATING YOUR FURNACE.**

PLEASE KEEP THIS MANUAL FOR REFERENCE

THANK YOU FOR CHOOSING THIS DROLET WOOD FURNACE

As one of North America's largest and most respected wood stove, furnace and fireplace manufacturers, Stove Builder International takes pride in the quality and performance of all its products. We want to help you get maximum satisfaction as you use this product.

In the pages that follow you will find general advice on wood heating, detailed instructions for safe and effective installation, and guidance on how to get the best performance from this furnace as you build and maintain fires, and maintain your wood heating system.

All local and national regulations, including those referring to national and European standards, shall be followed when installing this appliance.

We recommend that our wood burning hearth products be installed and serviced by professionals.

Congratulations on making a wise purchase.

When this furnace is not properly installed, a house fire may result. To reduce the risk of fire, follow the installation instructions. Contact local building or fire officials about restrictions and installation inspection requirements in your area.

Please read this entire manual before you install and use your new furnace. Failure to follow instructions may result in property damage, bodily injury, or even death. It is important that you follow the installations guidelines exactly.

You may need to obtain a building permit for the installation of this furnace and the chimney that it is connected to. Consult your municipal building department or fire department before installation to determine the need to obtain one. We recommend that you also inform your home insurance company to find out if the installation will affect your policy.

Table of contents

PART A - OPERATION AND MAINTENANCE	6
1 Safety information	6
1.1 Summary of operation and maintenance cautions and warnings	6
1.2 Smoke detector	7
1.3 Chimney fire	7
1.4 Prolonged power outage	7
2 General information.....	8
2.1 Drolet Tundra furnace specifications	8
2.1.1 Technical data Tundra	9
2.1.2 General technical data	10
2.2 The benefits of low emissions and high efficiency.....	11
2.3 The SBI commitment to you and the environment.....	11
2.3.1 What is your new furnace made of?.....	11
3 Operating your furnace	12
3.1 Your first fires	12
3.2 Lighting fires.....	12
3.2.1 Raking charcoal	13
3.2.2 Firing each new hot load	13
3.2.3 Control of the air supply	13
3.2.4 Building different fires for different needs.....	14
3.3 The use of a thermometer	15
3.3.1 Safety.....	16
3.3.2 Combustion efficiency.....	16
3.3.3 Protect your furnace.....	16
3.4 Control of the air inlet damper	16
3.5 Ash drawer	16
4 Maintaining your wood heating system.....	17
4.1 Furnace maintenance.....	17
4.1.1 Cleaning door glass	17
4.1.2 Door adjustment.....	18
4.1.3 Replacement of the glass and gaskets	19
4.1.4 Cleaning and painting the furnace	21
4.1.5 Heat exchangers care	21

- 4.2 Flue and flue system maintenance..... 25
 - 4.2.1 Why flue system cleaning is necessary..... 25
 - 4.2.2 How often should you clean the flue system? 25
- 4.3 Blower motor maintenance..... 25
- PART B - INSTALLATION.....26**
- 5 Safety information26**
 - 5.1 Summary of installation cautions and warnings 26
 - 5.2 Regulations covering furnace installation 26
 - 5.3 Connecting pipe, manual and barometric damper..... 26
 - 5.4 Flue system and draft..... 27
 - 5.5 Combustion air 28
 - 5.6 Filter 29
- 6 Setting up the unit and clearances29**
 - 6.1 Unit location 29
 - 6.2 Clearances to combustibile material 30
 - 6.3 Floor protector 33
 - 6.4 Hot air distribution system 34
 - 6.4.1 Authorized configurations..... 38
 - 6.4.2 Non-authorized configuration 39
- 7 The venting system39**
 - 7.1 General 39
 - 7.2 Suitable flue systems 39
 - 7.2.1 Factory-built metal flue systems..... 40
 - 7.2.2 Masonry flue systems 40
 - 7.3 Air supply in conventional houses 41
- 8 Electrical connections and controls41**
 - 8.1 Wiring diagram 41
 - 8.2 Manual or thermostat control..... 43
 - 8.3 Blower control 44

Appendix 1: Optional thermostat installation45
Appendix 2: Optional filter (AC01390)47
Appendix 3: Optional Fresh air return adapter (AC01392)48
Appendix 4: Installation of secondary air tubes and baffle49
Appendix 5: Troubleshooting.....51
Appendix 6: Exploded diagram and parts list.....52
DROLET LIMITED WARRANTY56

PART A - OPERATION AND MAINTENANCE

Please see Part B for installation instructions.

1 Safety information

1.1 Summary of operation and maintenance cautions and warnings

- **HOT WHILE IN OPERATION, KEEP CHILDREN, CLOTHING AND FURNITURE AWAY. CONTACT MAY CAUSE SKIN BURNS. GLOVES MAY BE NEEDED FOR FURNACE OPERATION.**
- **OPEN THE AIR CONTROL FULLY BEFORE OPENING FIRING DOOR.**
- **DO NOT USE AS AN INCINERATOR.**
- **DO NOT CONNECT THIS UNIT TO A CHIMNEY FLUE SERVING ANOTHER APPLIANCE.**
- **USING A FURNACE WITH CRACKED OR BROKEN COMPONENTS, SUCH AS GLASS OR FIREBRICKS OR BAFFLES MAY PRODUCE AN UNSAFE CONDITION AND MAY DAMAGE THE FURNACE.**
- **THIS FURNACE IS NOT DESIGNED TO BE USED WITH THE DOOR OPEN. THE DOOR MAY BE OPEN ONLY DURING LIGHTING PROCEDURES OR RELOADING. DO NOT LEAVE THE FURNACE UNATTENDED WHEN THE DOOR IS SLIGHTLY OPENED DURING IGNITION. ALWAYS CLOSE THE DOOR AFTER IGNITION.**
- **NEVER USE GASOLINE, GASOLINE-TYPE LANTERN FUEL (NAPHTHA), FUEL OIL, MOTOR OIL, KEROSENE, CHARCOAL LIGHTER FLUID, OR SIMILAR LIQUIDS OR AEROSOLS TO START OR 'FRESHEN UP' A FIRE IN THIS FURNACE. KEEP ALL SUCH LIQUIDS OR AEROSOLS WELL AWAY FROM THE FURNACE WHILE IT IS IN USE.**
- **DO NOT STORE FUEL WITHIN HEATER MINIMUM INSTALLATION CLEARANCES.**
- **BURN ONLY SEASONED NATURAL FIREWOOD.**
- **DO NOT BURN:**
 - **GARBAGE OF ANY KIND,**
 - **COAL OR CHARCOAL,**
 - **TREATED, PAINTED OR COATED WOOD,**
 - **PLYWOOD OR PARTICLE BOARD,**
 - **FINE PAPER, COLORED PAPER OR CARDBOARD,**
 - **SALT WATER DRIFTWOOD OR**
 - **RAILROAD TIES.**
- **DO NOT ELEVATE THE FIRE BY USING A GRATE IN THIS FURNACE.**
- **DO NOT INSTALL AN AUTOMATIC FEEDER ON THIS FURNACE.**
- **DO NOT INSTALL A MANUAL DAMPER ON THIS FURNACE.**
- **THIS APPLIANCE SHOULD BE MAINTAINED AND OPERATED AT ALL TIMES IN ACCORDANCE WITH THESE INSTRUCTIONS.**

1.2 Smoke detector

We highly recommend the use of a smoke detector. It must be installed at least 4.57 m from the appliance in order to prevent undue triggering of the detector when reloading.

1.3 Chimney fire

A Chimney fire will happen when the flame from an uncontrollable fire ignites the soot and creosote deposits in a neglected venting system. It will often happen when burning cardboard, branches or small dry pieces of wood. The first signs of a chimney fire are:

1. A rumble.
2. Smoke pipe becomes extremely hot.
3. Sparks or even flames shoot out of the chimney

In the event of a chimney fire, first call your local fire department and water the roof in the vicinity of the chimney.

Make sure that the furnace door and the air intake damper are closed (if need be, lower the thermostat setting and CLOSE the barometric draft damper manually if one is installed).

In the event of uncontrollable fire (caused by wrongful operation or excessive chimney draft), follow the same procedure as in a chimney fire but you must then OPEN the barometric draft damper manually if one is installed.

1.4 Prolonged power outage

To reduce the risk of overheating during a prolonged power outage (more than 10 minutes), it is recommended to keep the damper closed. If your furnace is equipped with the optional filter, remove the air filter to improve the circulation of air around the combustion chamber of the Tundra furnace. Do not load the furnace more than 50 percent of its capacity to prevent the risk of overheating,

2 General information

2.1 Drolet Tundra furnace specifications

Recommended fuel	Wood logs (Birch, Beech or Hornbeam)
Test Standard	EN 13240/A2
Type of combustion	Intermittent
Nominal heat output	25 kW
Flue gas temperature	340 °C
Thermostatic control	Optional
Efficiency (@ 25 kW)	77.1 %
Mean CO ₂ concentration	13.1 %
Approximate Burn Time*	9 to 10 hours
Reload time at nominal heat output	45 min
Color	Metallic black
Minimum flue draught (door closed)	10 Pa
Weight:	268 kg (with blower)
Firebox Volume	0.102 m ³
Loading capacity	Up to 25 kg
Type of door	Cast iron with ceramic glass
Maximum Log Length	518 mm
Recommended log length	330 mm
Log loading :	Over depth**
Flue Outlet Size	152 mm
Recommended smoke pipe dimension	152 mm
Recommended chimney size	152 mm
Dimensions of the hot air outlet	Four 203 mm round outlet
Dimensions of the cold air return	508 mm H x 381 mm L Optional
Dimensions of ash drawer	508 mm L x 111 mm D
Thickness of steel (firebox)	5 mm
Baffle Material	C-Cast
Recommended service clearance	610 mm

* Burn time and heating capacity may vary subject to hot air distribution system, chimney draft, chimney diameter, locality, heat loss factors, climate, fuels and other variables.

** Over width: through the door you see the sides of the logs; over depth: through the door you see the ends of the logs.

2.1.1 Technical data Tundra

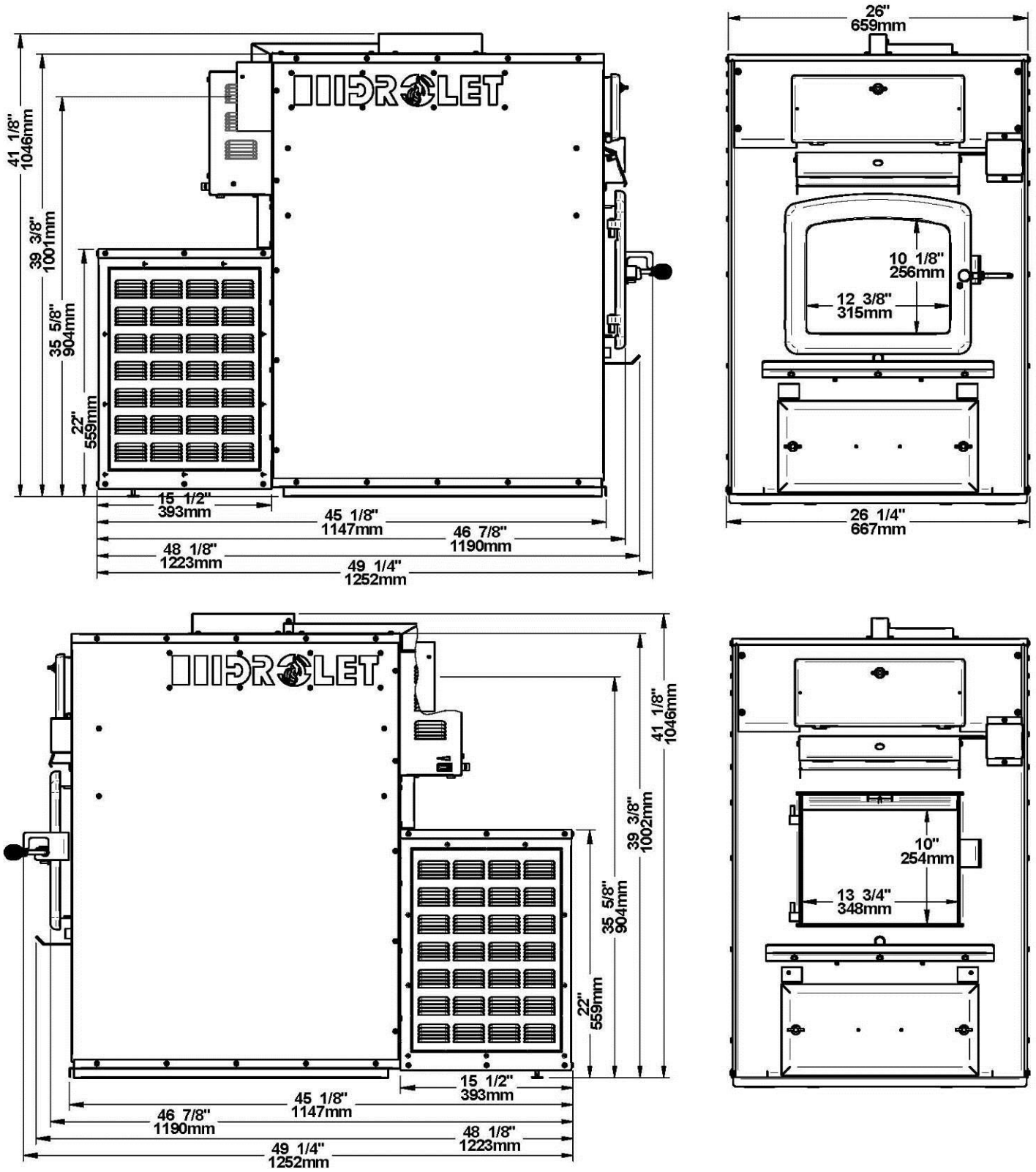

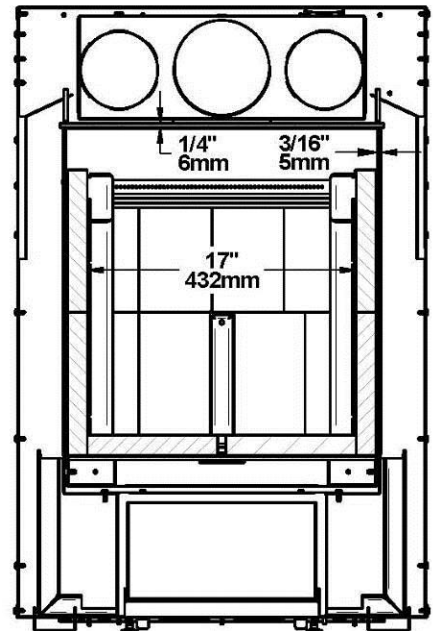
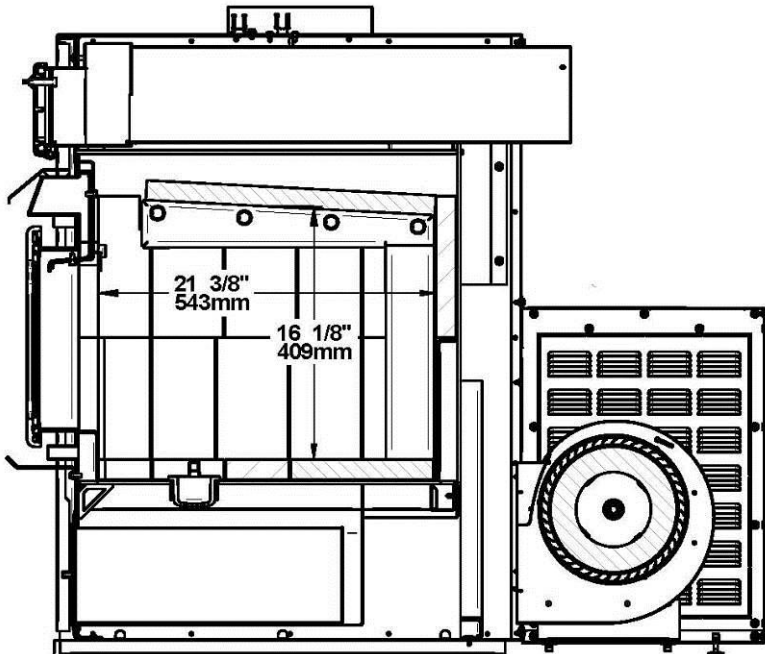
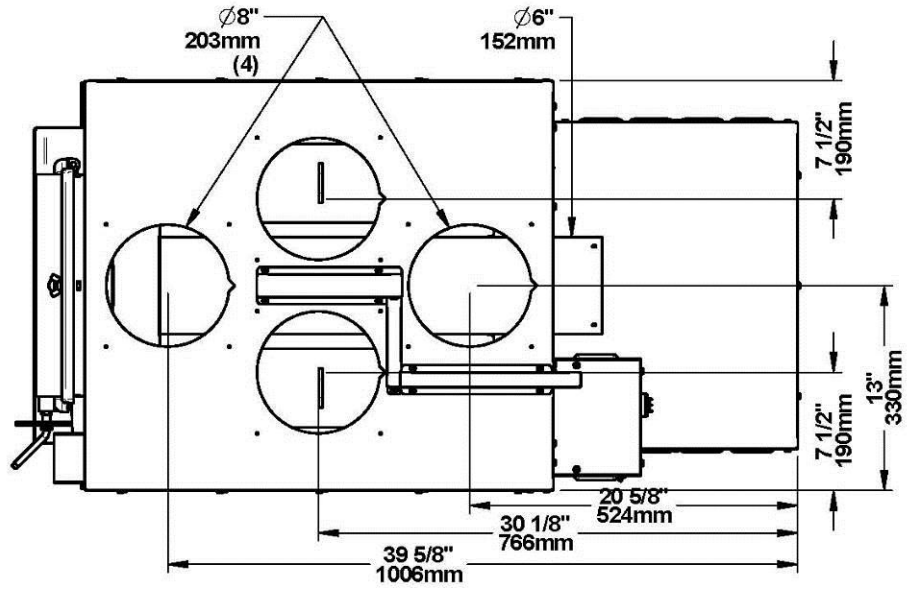

2.1.2 General technical data

MODEL	(DIRECT DRIVE)			FLOW (CFM)	TEMP VAR. (°C)	kW (WOOD)	STATIC PRESSURE Pa	OPTIONAL FILTER (mm)
	VENT	MOT.	VIT.					
TUNDRA	DCT-916-800-5	1/4	3	1400	57	36,7	50	508 x 381 x 25

2.2 The benefits of low emissions and high efficiency

The low smoke emissions produced by the special features inside the Drolet Tundra firebox mean that your household will release up to 90 percent less smoke into the outside environment than if you used an older conventional wood furnace. But there is more to the emission control technologies than protecting the environment.

The smoke released from wood when it is heated contains about half of the energy content of the fuel. By burning the wood completely, your furnace releases all the heat energy from the wood instead of wasting it as smoke up the chimney. Also, the features inside the firebox allow you to reduce the air supply to control heat output, while maintaining clean and efficient flaming combustion, which boosts the efficient delivery of heat to your home.

The emission control and advanced combustion features of your furnace can only work properly if your fuel is in the correct moisture content range of 15 to 20 percent.

2.3 The SBI commitment to you and the environment

The SBI team are committed to protecting the environment, so we do everything we can to use only materials in our products that will have no lasting negative impact on the environment.

2.3.1 What is your new furnace made of?

The body of your furnace, which is most of its weight, is carbon steel. Should it ever become necessary many years in the future, almost the entire furnace can be recycled into new products, thus eliminating the need to mine new materials.

The paint coat on your furnace is very thin. Its VOC content (Volatile Organic Components) is very low. VOCs can be responsible for smog, so all the paint used during the manufacturing process meets the latest air quality requirements with regards to VOC reduction or elimination.

The air tubes are stainless steel, which can also be recycled.

The C-Cast baffle is made of an aluminosilicate fibre material that is compressed with a binder to form a rigid board. C-Cast can withstand temperatures above 1093 °C. It is not considered hazardous waste. Disposal at a landfill is recommended.

Lightweight firebrick is made of pumice and cement. Pumice is in fact volcanic rock, a naturally green product found in the Northwest United States. Disposal at a landfill is recommended.

The door and glass gaskets are fibreglass which is spun from melted sand. Black gaskets have been dipped into a solvent-free solution. Disposal at a landfill is recommended.

The door glass is a 5 mm thick ceramic material that contains no toxic chemicals. It is basically made of raw earth materials such as sand and quartz that are combined in such a way to form a glass at high temperatures. Ceramic glass will not re-melt in the same way as normal glass, so it should not be recycled with your regular household products. Disposal at a landfill is recommended.

3 Operating your furnace

- **NEVER OVERFIRE YOUR WOOD FURNACE. IF ANY PART OF THE WOOD FURNACE STARTS TO GLOW RED, OVER FIRING IS HAPPENING. CLOSE THE AIR INTAKE.**
- **NEVER LOAD YOUR WOOD FURNACE UP TO THE BAFFLE. ALWAYS LEAVE 5 TO 10 CENTIMETERS TO ALLOW PROPER COMBUSTION THROUGH SECONDARY AIR OPENINGS (NEVER PUT WOOD ABOVE THE FIREBRICK LINING ON THE FIREBOX). THIS WILL ALSO PREVENT OVERFIRING OF YOUR WOOD FURNACE.**
- **SHOULD THERE BE SOOT OR CREOSOTE FIRE IN YOUR FLUE SYSTEM ALSO CALLED CHIMNEY FIRE, CLOSE THE AIR CONTROL COMPLETELY. IMMEDIATELY CALL THE FIRE DEPARTMENT.**

3.1 Your first fires

Two things will happen as you burn your first few fires; the paint cures and the internal components of the furnace are conditioned.

As the paint cures, some of the chemicals vaporize. The vapours are not poisonous, but they do smell bad. Fresh paint fumes can also cause false alarms in smoke detectors. So, when you first light your furnace, be prepared by opening doors and/or windows to ventilate the house. As you burn hotter and hotter fires, more of the painted surfaces reach the curing temperature of the paint. The smell of curing paint does not disappear until you have burned one or two very hot fires.

It is recommended to burn it at high rate and ventilate the building until the odours disappear. Once the paint smell disappears, your furnace is ready for serious heating.

3.2 Lighting fires

Each person who heats with wood develops their own favourite method to light fires. Whatever method you choose, your goal should be to get a hot fire burning quickly. A fire that starts fast produces less smoke and deposits less creosote in the flue system.

IF YOU MUST OPEN THE DOOR WHILE THE FUEL IS FLAMING, OPEN THE AIR CONTROL FULLY FOR A FEW MINUTES, THEN UNLATCH AND OPEN THE DOOR SLOWLY.

IMPORTANT

WHEN RELOADING, MAKE SURE YOU KEEP THE AIR INLETS LOCATED BELOW THE DOOR INSIDE THE COMBUSTION CHAMBER FREE OF ASH.

OPENING PROCEDURE FOR THE LOADING DOOR

TO MINIMISE THE RISK OF SMOKE SPILLAGE, CRACK THE DOOR OPEN ABOUT AN 2.5 CM AND WAIT ABOUT 10 SECONDS BEFORE OPENING IT WIDE TO ALLOW STABILISATION OF THE PRESSURE INSIDE THE FURNACE.

3.2.1 Raking charcoal

Rekindle the fire when you notice that the room temperature has fallen. Do not operate your furnace at too low a setting. Keep the air inlet opened long enough during the fire start-up to prevent the fire from smouldering, which could stain the glass. You will find most of the remaining charcoal at the back of the firebox, furthest from the door. Rake these coals towards the door before loading. There are two reasons for this raking of the coals. First, it concentrates them near where most of the combustion air enters the firebox and where they can ignite the new load quickly, and second, the charcoal will not be smothered by the new load of wood. If you were to simply spread the charcoal out, the new load will smoulder for a long time before igniting.

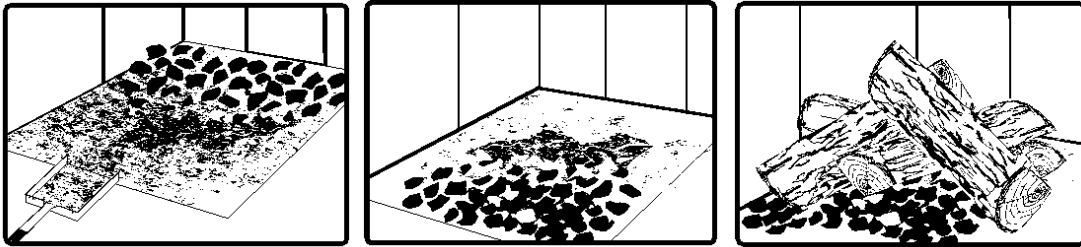

Remove ash first, and then rake charcoal towards the front of the firebox before loading so that it will ignite the new load.

3.2.2 Firing each new hot load

Place the new load of wood on and behind the charcoal, and not too close to the glass. Close the door and open the air control fully. Leave the air control fully open until the firebox is full of flames, the wood has charred to black and its edges are glowing red. Firing each load of wood hot accomplishes a few things:

- drives the surface moisture from the wood,
- creates a layer of char on the wood, which slows down its release of smoke,
- heats the firebox components so they reflect heat back to the fire, and
- heat the chimney so it can produce strong, steady draft for the rest of the cycle.

DO NOT LEAVE THE FURNACE UNATTENDED WHILE A NEW LOAD IS BEING FIRED HOT.

DO NOT OVERFIRE.

When you burn a new load of wood hot to heat up the wood, the furnace and the chimney, the result will be a surge of heat from the furnace. This heat surge is welcome when the room temperature is a little lower than desirable, but not welcome if the space is already warm. Therefore, allow each load of wood to burn down so that the space begins to cool off a little before loading. Letting the space cool before loading is one of the secrets to clean burning and effective zone heating.

3.2.3 Control of the air supply

Once the firewood, firebox and chimney are hot, you can close the air supply for a steady burn.

If the flames get very small and almost disappear when you close the air, you have closed the air too early, or your firewood is wetter than it should be. With good fuel and correct air control use, the flames should slow down, but should stay large and steady, even as the air supply is closed.

When the furnace is using a thermostat, it is the thermostat that controls the air inlet damper. When the thermostat calls for heat, the damper opens and the combustion is stirred up. When the furnace gets hot enough, the thermodisc activates the blower motor.

The following figure shows the position of the air inlet damper according to the position of the air inlet damper switch.

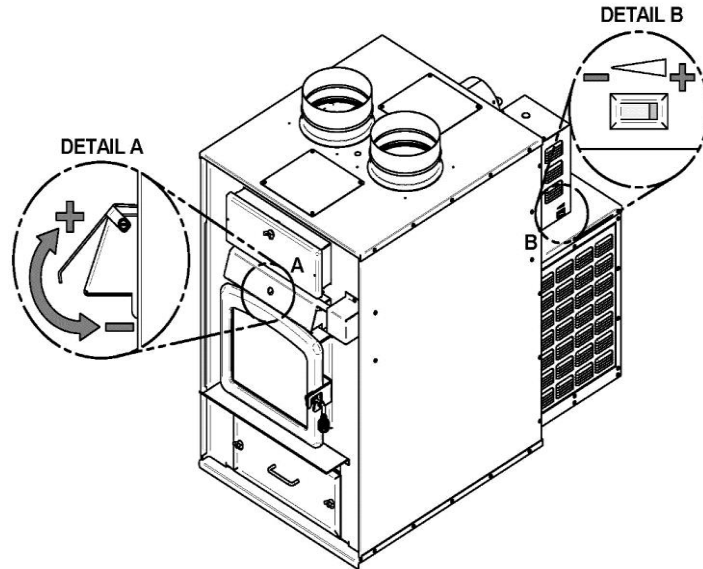

3.2.4 Building different fires for different needs

Using the air control is not the only way to match the furnace's heat output to the heat demand. Your house will need far less heat in October than in January to be kept at a comfortable temperature. If you fill the firebox full in fall weather, you will either overheat the space or turn the furnace down so much that the fire will be smoky and inefficient. Here are some suggestions for building fires to match different heat demand.

3.2.4.1 Small fires to take the chill off the house

To build a small fire that will produce a low heat output, use small pieces of firewood and load them crisscross in the firebox. The pieces should be only 76 mm to 102 mm in diameter. After raking the coals, you can lay two pieces parallel to each other corner to corner in the firebox and lay two more across them in the other direction. Open the air control fully and only reduce the air after the wood is fully flaming. This kind of fire is good for mild weather when you are around to tend the furnace and should provide enough heat for four hours or more. Small fires like this are a good time to use softer wood species so there will be less chance of overheating the house.

3.2.4.2 Long lasting low output fires

Sometimes you will want to build a fire to last up to eight hours, but don't need intense heat. In this case use soft wood species and place the logs compactly in the firebox so the

pieces are packed tightly together. You will need to fire the load hot for long enough to fully char the log surfaces before you can turn the air down. Make sure the fire is flaming brightly before leaving the fire to burn.

3.2.4.3 High output fires for cold weather

When the heat demand is high during cold weather, you'll need a fire that burns steadily and brightly. This is the time to use your biggest pieces of hardwood fuel if you have it. Put the biggest pieces at the back of the firebox and place the rest of the pieces compactly. A densely built fire like this will produce the longest burn your furnace is capable of.

You will need to be cautious when building fires like this because if the air is turned down too much, the fire could smoulder. Make sure the wood is flaming brightly before leaving the fire to burn.

3.2.4.4 Maximum burn cycle times

The burn cycle time is the period between loading wood on a coal bed and the consumption of that wood back to a coal bed of the same size. The flaming phase of the fire lasts for roughly the first half of the burn cycle and the second half is the coal bed phase during which there is little or no flame. The length of burn you can expect from your furnace, including both the flaming and coal bed phases, will be affected by a number of things, such as:

- firebox size,
- the amount of wood loaded,
- the species of wood you burn,
- the wood moisture content,
- the size of the space to be heated,
- the climate zone you live in, and
- the time of year.
- the time cycle for the thermostat to call for heat.

The table below provides a very general indication of the maximum burn cycle times you are likely to experience, based on firebox volume.

FIREBOX VOLUME	MAXIMUM BURN TIME
< 0.042 cubic meter	3 to 5 hours
0.042 m ³ to 0.056 m ³	5 to 6 hours
0.056 m ³ to 0.071 m ³	6 to 8 hours
0.071 m ³ to 0.085 m ³	8 to 9 hours
> 0.085 m ³	9 to 10 hours

3.3 The use of a thermometer

There are several factors favoring the use of a chimney thermometer. There are two types of thermometers, magnetic thermometers and probe thermometers. The two types of thermometers have the same advantage; magnetic thermometer is designed for single wall pipe and the probe for double-wall pipes. The first use of a thermometer is to inform the

user about the discharge temperature of flue gases. The thermometer will indicate if the temperature is ideal, too low or too high. Use the thermometer to better control the heat of the furnace.

3.3.1 Safety

Too low temperatures, usually indicates that the fire is too low and the smoke is very apparent, which increases the risk of accumulation of creosote in the pipe and thus increases the risk of chimney fire.

3.3.2 Combustion efficiency

Even the best-built wood furnaces should be well used to obtain maximum efficiency. A furnace that overheats will not transfer more heat to the inside, as this will increase the heat loss through the chimney. Using a thermometer will help you control the temperature of your furnace and achieve optimum performance when controlled manually.

3.3.3 Protect your furnace

It is impossible to determine the temperature of the chimney flue and the furnace by a simple look at the flames. A thermometer tells you when the fire is too hot, which helps you avoid damages to the components of the combustion chamber therefore prolong its service life.

3.4 Control of the air inlet damper

Always turn the furnace on with the air inlet damper open. Once the temperature of the wood, the combustion chamber and the chimney is stable, close the air inlet damper to obtain a more efficient combustion.

To control the air inlet damper, use the switch on the side of the control box located at the back of the furnace.

Closing the combustion air will do two things. First, the combustion rate will decrease, which will spread the thermal energy of the fuel over a longer period of time. In addition, the velocity of the exhaust gas decreases, which allows better heat transfer in the heat exchanger and chimney.

The closure of the main air intake reduces the intensity of the flames which indicates the achievement of optimum performance. If the flames diminish in intensity at a point where it almost disappears, it is an indication that the air inlet damper was closed too soon or the firewood used is dry enough. If the wood is dry enough and the air control is closed when the unit is at a stable temperature, the flames will decrease but remain strong and stable to provide efficient heating.

For ease of use, an optional thermostat can be easily added to the furnace which would automatically control the air inlet damper to keep the temperature stable. For complete information about this option, refer to **Appendix 1: *Optional thermostat installation.***

3.5 Ash drawer

Your furnace is equipped with an ash drawer to collect ashes produced by the combustion of wood. The ash drawer is provided with two (2) wing nuts to hold the door in a close position. Operating the furnace with the ash drawer open may seriously damage the furnace. **The drawer must be emptied regularly.**

WARNING: IT IS IMPORTANT THAT THE FIRING DOOR, THE ASH DRAWER AND THE ASHPLUG BE KEPT CLOSED WHILE THE APPLIANCE IS IN USE. MAINTAIN ALL GASKETS, IF ANY, IN GOOD CONDITION; IN CASE OF DETERIORATION, CONTACT YOUR DEALER FOR A GENUINE REPLACEMENT GASKET.

4 Maintaining your wood heating system

Maintenance should be performed by a competent engineer.

4.1 Furnace maintenance

Your new furnace will give many years of reliable service if you use and maintain it correctly. Some of the internal components of the firebox, such as firebricks, baffles and air tubes, will wear over time under intense heat. You should always replace defective parts with original parts (see **Appendix 6: Exploded diagram and parts list**). For firing each load hot to begin a cycle as described above will not cause premature deterioration of the furnace. However, letting the furnace run with the air control fully open for entire cycles can cause damage over time. The hotter you run the furnace throughout burn cycles, the more quickly its components will deteriorate. For that reason, **never leave the furnace unattended while a new load is being fired hot.**

4.1.1 Cleaning door glass

Under normal conditions, your door glass should stay relatively clear. If your firewood is dry enough and you follow the operating instructions in this manual, a whitish, dusty deposit will form on the inside of the glass after a week or so of use. This is normal and can be easily removed when the furnace is cool by wiping with a damp cloth or paper towel and then drying. **Never try to clean the glass when the furnace is hot.**

In spring and fall the furnace will cycle less often. You may see some light brown stains forming, especially at the lower corners of the glass. This indicates that the combustion has been incomplete and some of the smoke has condensed on the glass. When the weather is mild, you may find that letting the fire go out is better than trying to maintain a continuous fire. Use the technique described above for building a fire to take the chill off the house.

If you do get brown stains on the glass you can remove them with special cleaners for wood furnace glass doors. **Do not use abrasives to clean your furnace's door glass.**

The deposits that form on the glass are the best indication of the quality of your fuel and how well you are doing in operating the furnace. Your goal should be clear glass with no brown stains. If you continue to see brown stains on the glass, something about your fuel and operating procedure needs to be changed. Stains on the glass indicate incomplete combustion of the wood, which also means more smoke emissions and faster formation of creosote in the chimney.

If you see brown streaks coming from the edge of the glass, it is time to replace the gasket around the glass. Visit your furnace retailer to get the self-adhesive glass gasket and

follow the **Section 4.1.3: Replacement of the glass and gaskets** instructions for installation.

- Check the glass regularly to detect any crack or damage. Replace damaged glass immediately; do not use the furnace with a broken glass.

4.1.2 Door adjustment

In order for your furnace to burn at its best efficiency, the door must provide a perfect seal with the firebox. Therefore, the gasket should be inspected periodically making sure to obtain an air tight fit. Air tightness can be improved with a simple latch mechanism adjustment. If the adjustment is not sufficient, replace the door gasket with a new one.

Door adjustment procedure

1. Unscrew the locking pin **(B)** and nut **(A)** from the door (see image below).
2. To increase the pressure of the door on the gasket, turn the handle. Counter-clockwise, to reduce the pressure of the door on the gasket, turn the handle clockwise to clockwise.
3. Finally, screw-in the locking pin **(B)** about 6 mm deep and make sure you lock it with the nut **(A)**.

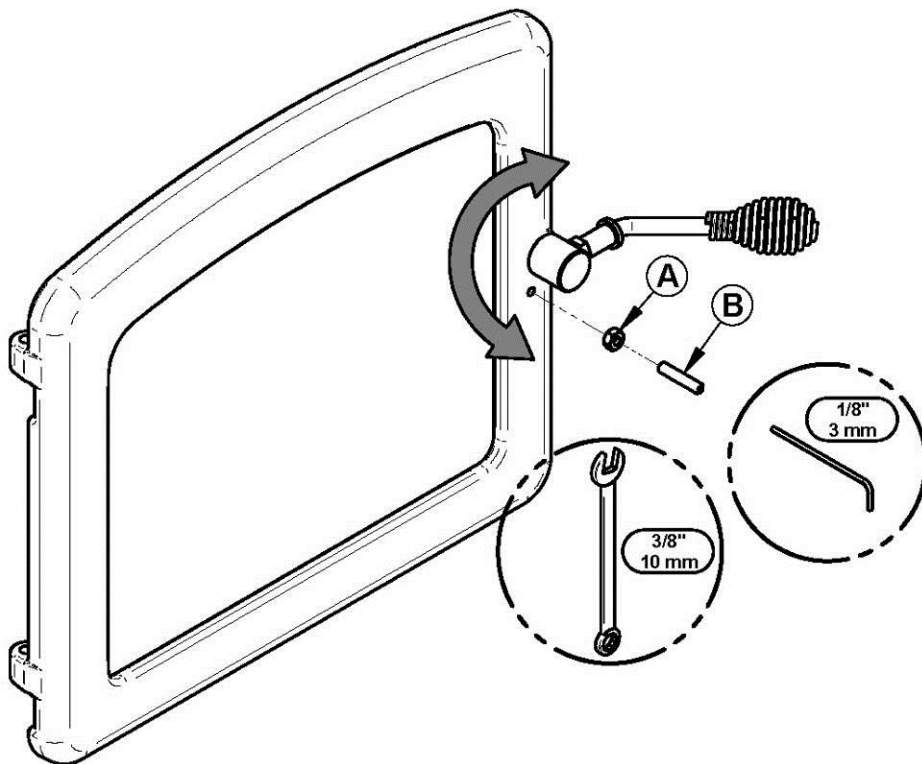

4.1.3 Replacement of the glass and gaskets

After a year or more of use, the gasket of the door will compress and become hard which can allow air to pass. You can check the air tightness of your door gasket by closing and locking the door on a piece of paper. Check all around the door. If the paper slides easily anywhere, it is time to replace the gasket.

Use a good quality gasket that you can purchase from your dealer. The correct size and density of the gasket are important to ensure a good seal.

Prior of removing the defective glass, you need to remove the door gasket. Inspect the door gasket before it is reinstalled to make sure it is in good condition. We suggest replacing the door and glass gasket at the same time as their level of wear over time is similar.

For the following steps, wearing gloves and safety glasses are recommended for handling seals can irritate the skin and the glass can be sharp.

To replace the door gasket, use the steps 1 to 3 and 10 outlined below;

To replace the glass, use the steps 1 to 6 and 9 to 10 outlined below;

To replace the glass gasket, use the steps 1 to 10 outlined below;

1. Remove the door **(F)** and place it on a stable work surface, handle down.
2. Using pliers, remove the door gasket **(A)**.
3. Using a scraper or a small flat screwdriver, remove the adhesive left in the gasket groove in the door then clean the surface using a commercial vacuum.
4. Use a cruciform (Philips) screwdriver or a power drill to remove the screws **(B)** that holds the glass retainer **(C)**.
5. Remove the glass frame **(D)**
6. Remove the glass **(E)** (or pieces of glass if it is damaged) and clean the inside of the door frame.
7. Remove the old glass gasket.
8. Install the new gasket on the glass. Remove a part of the paper covering the gasket adhesive. Center the gasket on the edge of the glass so that when folded and glued, the gasket is equal on both sides. Do not stretch the gasket during installation. Remove a majority of the paper, turn the glass to facilitate and complete the installation of the gasket. When you return to the starting point, cut the gasket so that the ends overlap by about 13 mm.

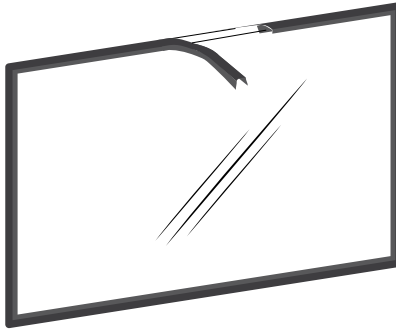

9. Install the glass (E) and glass frame (D) and centering it in the frame of the door and install the glass frame (D) and glass retainers (C) taking care not to over tighten the screws (B). Note that the two main causes of glass breakage are unequal position in the door and screws too tight.
10. Install the new door gasket (A). To do this, use about 6 mm of adhesive to the bottom of the groove that holds the gasket in the door. Then lay the new gasket starting from the center of the hinge side and taking care not to stretch the gasket during installation. Leave about 6 mm of gasket exceed the frame of the door. Once jointed, push the fibers protruding towards the inside of the groove in the adhesive. Install the door and let dry for 24 hours before using the furnace.

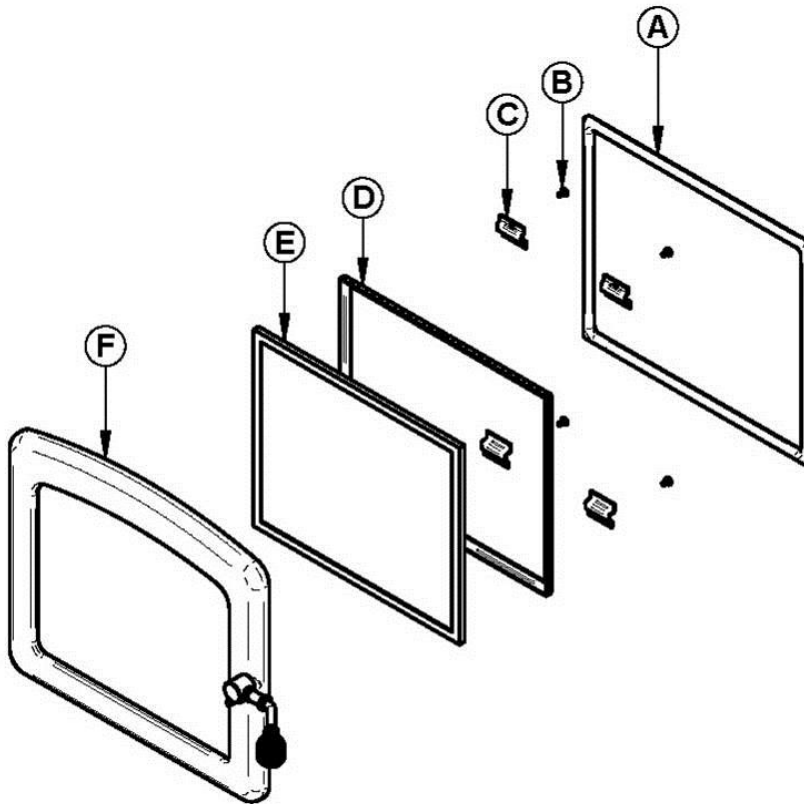

Do not abuse the glass door by striking or slamming shut. Do not use the furnace if the glass is broken. To change the glass, perform the same operation described above.

4.1.4 Cleaning and painting the furnace

Do not attempt to clean or paint the furnace when the unit is hot. Painted surfaces can be wiped down with a damp cloth. Plated or enameled surfaces may be scratched by abrasive cleaners. To maintain the finish at its original brilliance, use only a damp soft cloth to clean plated or enameled surfaces.

If the paint becomes scratched or damaged, you can give your wood furnace a brand new look by repainting it with heat-resistant or enamel finish paint. Before painting, roughen the surface with fine sand paper, wipe it down to remove dust, and apply two thin coats of paint. For best results, use the same paint that was originally used on the furnace, which is available in spray cans. See your dealer for details.

4.1.5 Heat exchangers care

Heat exchangers must be cleaned thoroughly at the end of every heating season. During summer, the air in basements is damper and with minimal air circulation within the furnace, it can mix with creosote and/or soot deposits in the exchangers to form an acid that could accelerate the corrosion process and induce premature decay of the steel. Corrosion damages are not covered under warranty.

Smoke pipe and exchangers must be inspected regularly during the heating season. Access to the exchangers is easy and does not require tools;

1. Unscrew the wing nut (**B**) and remove the washer (**C**) on the exchanger access door.

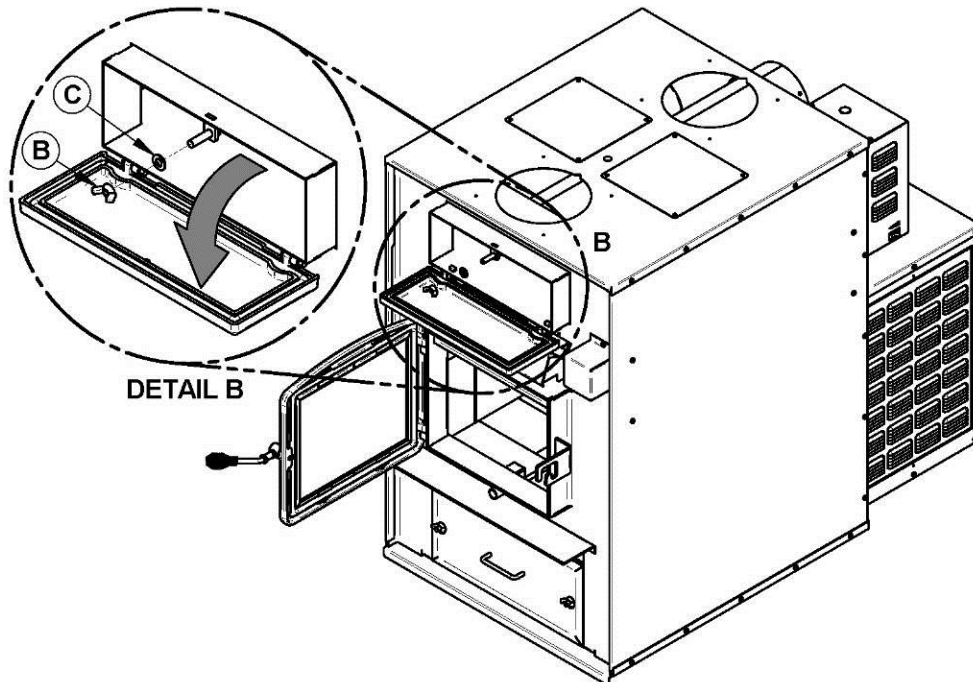

2. Move the baffle of the combustion chamber forward.

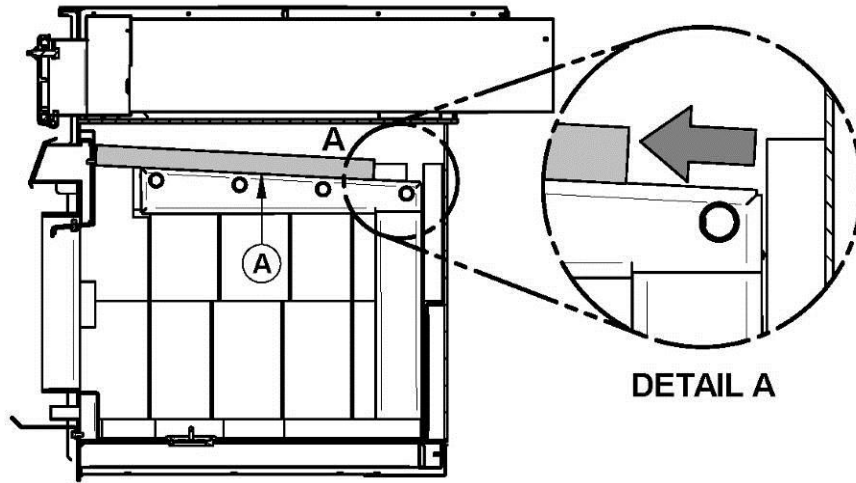

3. Use the tool provided to clean the three exchanger pipes.

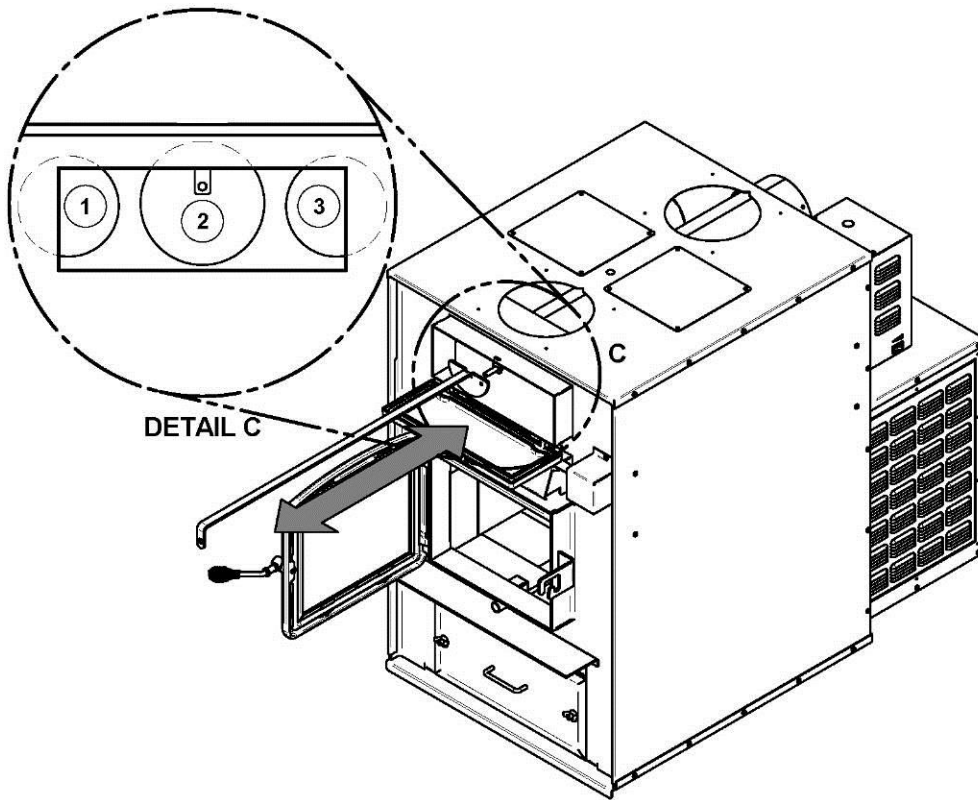

- Dirt in the lateral exchangers fall into the combustion chamber at the rear.

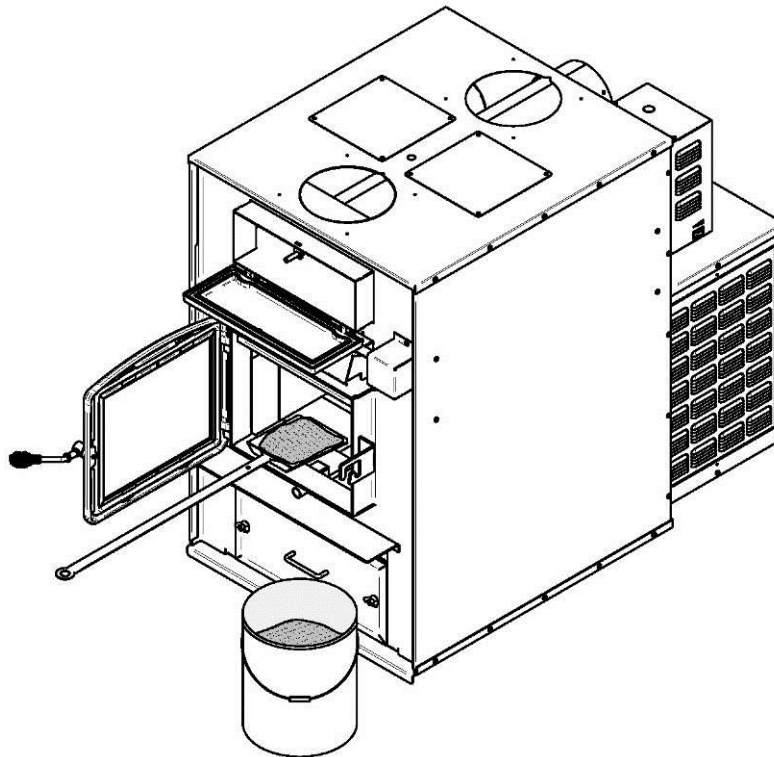
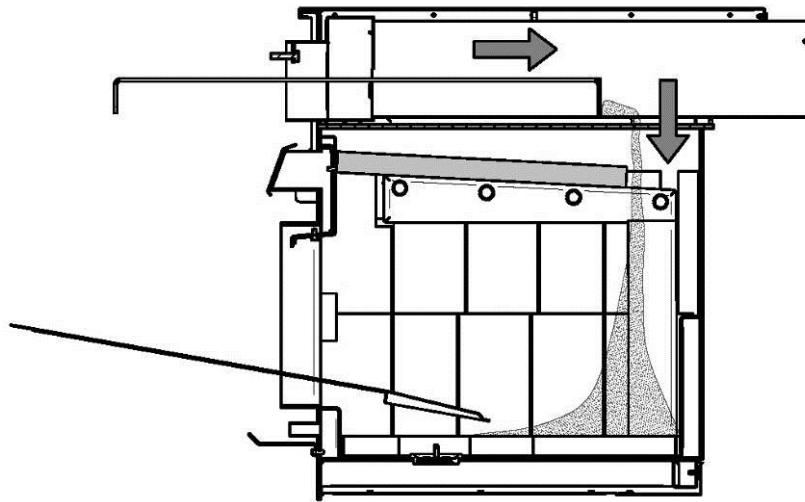

- Dirt in the central exchanger will be removed from the front or the rear of the furnace. If you remove dirt from the central exchange to the back of the furnace, remove the black pipe connector in order to dispose of the dirt.

- Then, check that the baffle is clear of ash and reposition it in its original position towards the back of the combustion chamber.

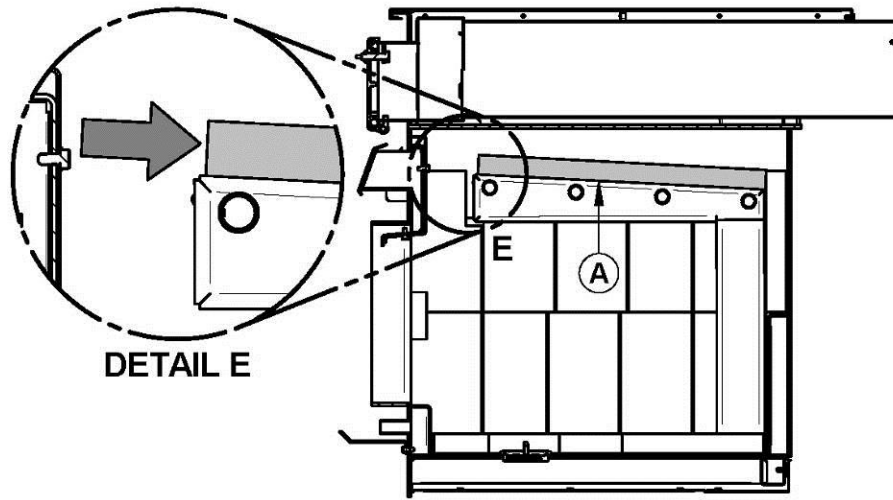

- Close the exchanger access door and secure it using the washer (C) and wing nut (B).

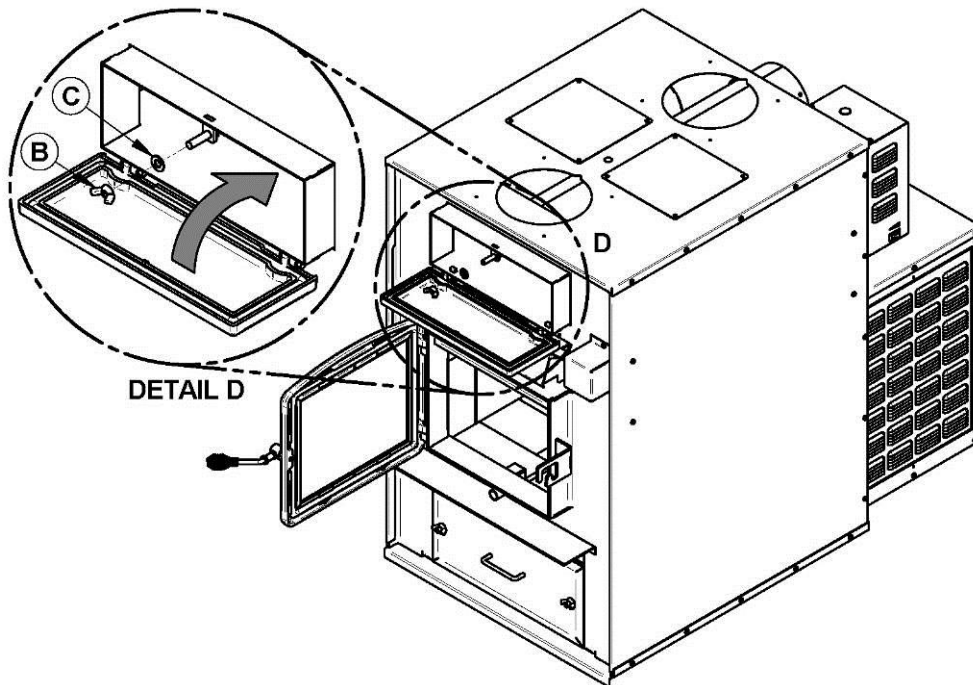

- If you have performed maintenance from the back part of the furnace, reinstall the black pipe connector and secure it with three screws.

4.2 Flue and flue system maintenance

4.2.1 Why flue system cleaning is necessary

Wood smoke can condense inside the flue and flue system, forming a combustible deposit called creosote. If creosote is allowed to build up in the flue system it can ignite when a hot fire is burned in the furnace and a very hot fire can progress to the top of the flue system. Severe flue system fires can damage even the best flue systems. Smouldering, smoky fires can quickly cause a thick layer of creosote to form. When you avoid smouldering so the exhaust from the flue system is mostly clear, creosote builds up more slowly. Your new furnace has the right characteristics to help you to burn clean fires with little or no smoke, resulting in less creosote in the flue system.

4.2.2 How often should you clean the flue system?

It is not possible to predict how much or how quickly creosote will form in your flue system. It is important, therefore, to check the build-up in your flue system monthly when getting used to the new furnace until you determine the rate of creosote formation. Even if creosote forms slowly in your system, the flue system should be cleaned and inspected at least once each year.

Contact your local municipal or provincial fire authority for information on how to handle a flue system fire. Have a clearly understood plan to handle a flue system fire.

WARNING: IT IS RECOMMENDED TO CLEAN THE HEAT EXCHANGERS THOROUGHLY AT THE END OF SEASON IN ORDER TO PREVENT CORROSION.

4.3 Blower motor maintenance

Periodic cleaning of the blower housing and louvers as well as blower and blower blades using a vacuum cleaner is necessary in order not to affect performance and cause overheating of the latter.

PART B - INSTALLATION

5 Safety information

5.1 Summary of installation cautions and warnings

- **MIXING OF APPLIANCE COMPONENTS FROM DIFFERENT SOURCES OR MODIFYING COMPONENTS MAY RESULT IN HAZARDOUS CONDITIONS. WHERE ANY SUCH CHANGES ARE PLANNED, FURNACE BUILDER INTERNATIONAL INC. SHOULD BE CONTACTED IN ADVANCE.**
- **ANY MODIFICATION OF THE APPLIANCE THAT HAS NOT BEEN APPROVED IN WRITING BY THE TESTING AUTHORITY VIOLATES BUILDING CODES.**
- **IF REQUIRED, A SUPPLY OF COMBUSTION AIR SHALL BE PROVIDED TO THE ROOM OR SPACE.**

5.2 Regulations covering furnace installation

<u>WARNING</u> RESPECT THE LOCAL CODES (WHEN IN DOUBT, CONSULT YOUR LOCAL DEALER).

Before installation, please read the instructions carefully and make sure you understand them:

Inspect the furnace to make sure that nothing has been damaged in the shipping. Pull out the instruction manual from the firebox of the furnace and the accessories from the flue pipe and/or exchangers.

- The blower speed should respect the static pressure ranges in the warm air plenum of the furnace (see **Section 2.1.2, *General technical data***).

5.3 Connecting pipe, manual and barometric damper

<u>WARNING:</u> DO NOT INSTALL A MANUAL DAMPER ON THIS FURNACE.
--

Here are some tips for proper installation:

We recommend that the connecting pipe and flue system have a 152 mm inside diameter. The minimum draft required at all times is -10 Pa but the furnace will perform at its best with a draft of -15 Pa.

Slightly higher draft is acceptable and a barometric draft control is not normally required on this unit but a barometric control must be installed to control excessive draft (more than -20 Pa.).

If a barometric damper must be installed, it must be adjusted to the maximum draft measured at the output of the furnace to -15 Pa. Please note that a draft greater than -20 Pa. could produce runaway (uncontrolled fire) of the furnace. The minimum draft required is -10 Pa. in the exhaust pipe.

A minimum rise of 6.5 mm per every 305 mm horizontal run must be respected.

5.4 Flue system and draft

This furnace must be connected to a flue system certified for wood burning heating appliances; a 152 mm connector and flue system is mandatory. The barometric damper must be adjusted so that the maximum draft measured at the furnace outlet is limited to -5 Pa. **However, the minimum draft to be respected at all times is -10 Pa in the evacuation pipe.**

If the flue system draft exceeds -15 Pa a barometric draft control should be installed on the smoke pipe. Never install a manual damper.

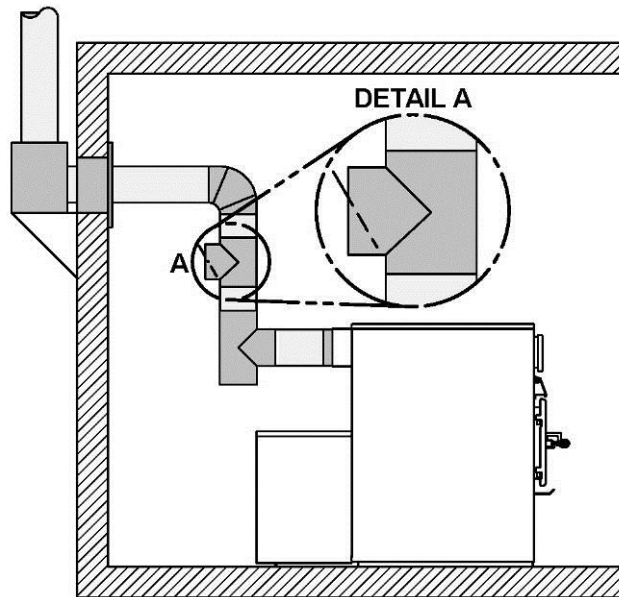

The barometric control must be adjusted so that the maximum draft measured at the furnace outlet does not exceed -15 Pa. Please note that a draft exceeding -15 Pa will reduce the efficiency and could produce an uncontrollable fire. **On the other hand, the minimum draft required is -10 Pa in the evacuation pipe on the wood side, no matter what type of furnace.**

CAUTION: BEFORE THE FLUE SYSTEM IS INSTALLED, MAKE SURE THAT THE EXHAUST PIPE AND / OR THE EXCHANGERS OF THE FURNACE ARE FREE OF ALL ITEMS.

WARNING: EXCESSIVE DRAFT MAY CAUSE OVERHEATING AND MAKE THE CONTROL OF THE FIRE DIFFICULT.

5.5 Combustion air

When the furnace and the flue system are completely cold, it may be necessary to provide fresh air by opening a door or a window for a few minutes while lighting the fire.

Take note that a house constructed or renovated in order to be airtight may lack the volume of fresh air necessary for the proper combustion of a solid-fuel heating appliance.

In such a case, when starting up the fire, do not operate appliances that evacuate air outside the house, such as:

- Range hood
- Air exchanger
- Clothes dryer
- Bathroom fan
- Ventilated central vacuum system

Exhaust blowers that are in a fuel storage room should be installed so as not to create negative pressure in the room where the solid fuel appliance is located.

A fresh air supply may be necessary to prevent solid fuel units from rejecting products of combustion into the house. The indications used to determine if an additional fresh air supply is necessary are not appropriate for all the situations. When in doubt, it is recommended to install a fresh air supply.

A fresh air supply may be needed if:

- Solid fuel units present anomalies, such as irregular draft, smoke return, bad combustion, and/or reversed draft (whether there is combustion or not);
- Existing solid fuel units such as a stove or fireplace release odours, heat badly, cause smoke returns, or reversed draft (whether there is combustion or not);
- The opening of a window, even slightly, in calm weather (windless), eliminates every problem mentioned above ;
- The house is equipped with a tight vapour barrier and adjusted windows, and/or is equipped with an interior air mechanical evacuation device ;
- There is excessive condensation on the windows in winter; and
- The house is equipped with a ventilation system.

If, according to these symptoms or other similar ones, there is insufficient combustion air, it is necessary to ensure an additional combustion air supply.

Additional combustion air can be provided following the following methods:

- Direct connection: solid fuel units can be connected directly to a source of new combustion air only if they are certified for this kind of installation, which must respect the manufacturer's instructions.

- Indirect method: new combustion air can be brought into a pipe located within approximately 300 mm of the unit. If the pipe is too close to the furnace, it may interfere with its operation.
- Mechanical ventilation system: if the house is equipped with a ventilation system (air exchanger or heat recovery), the ventilation system may provide sufficient auxiliary air to the solid fuel unit. Otherwise, the owner should be informed that the ventilation system may have to be rebalanced by a ventilation technician after the installation of the solid fuel unit.

WARNING: SUFFICIENT COMBUSTION AIR MUST BE AVAILABLE AT ALL TIMES; LACK OF COMBUSTION AIR CONSTITUTES A DANGER.

NOTE:

It is recommended to install an outside air inlet with a diameter of at least 102 mm in the room where the furnace appliance is installed (see drawing below). It is preferable to choose a wall which is exposed to dominant winds, depending on the conditions surrounding the house.

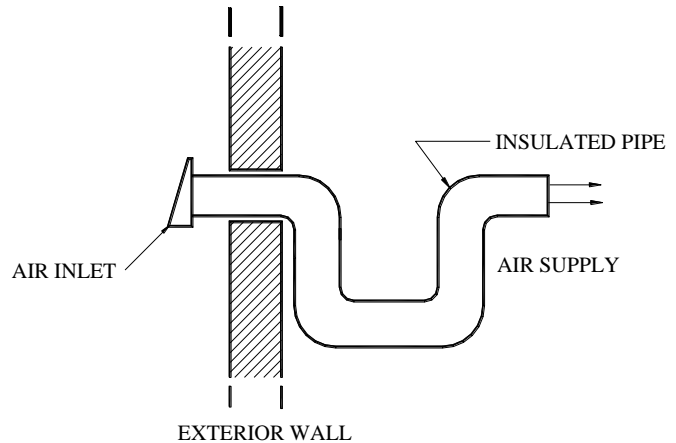

5.6 Filter

Even though this furnace is not equipped with a filter, we strongly recommend the installation of the optional filter kit, sold separately. See **Appendix 2: *Optional Filter (AC01390)***.

N.B.: THE OWNER OF THE FURNACE IS RESPONSIBLE FOR THE ROOM'S AIR QUALITY IN CASE OF NEGATIVE PRESSURE OR TEMPORARY NEGATIVE PRESSURE.

6 Setting up the unit and clearances

6.1 Unit location

The furnace must be installed where outside air supply will be sufficient for proper combustion. In airtight houses, it might be necessary to install an outside air inlet (see details in **Section 5.5: *Combustion air***.)

The furnace must be positioned so that the connector is as short as possible. Minimize the use of 90° elbows and horizontal lengths.

The owner must ensure a proper installation to allow a safe operation of the appliance.

6.2 Clearances to combustible material

The clearances shown in this section have been determined by test according to procedures set out in safety standards EN 13240. When the furnace is installed so that its surfaces are at or beyond the minimum clearances specified, combustible surfaces will not overheat under normal and even abnormal operating conditions.

No part of the furnace or flue system may be located closer to combustibles than the minimum clearance figures given.

N.B.: THIS APPLIANCE MUST BE INSTALLED IN ACCORDANCE WITH THE INSTRUCTIONS ON THE CERTIFICATION LABEL APPLIED ON THE UNIT.

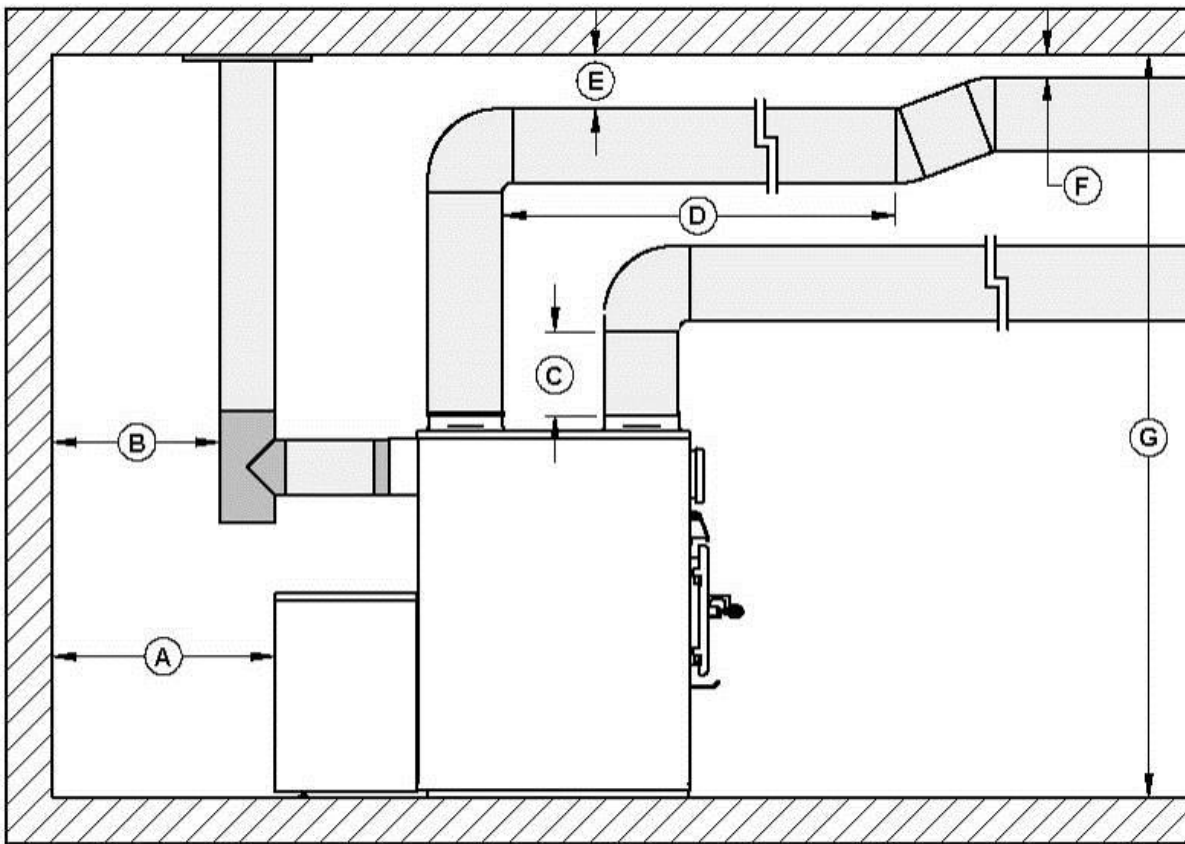

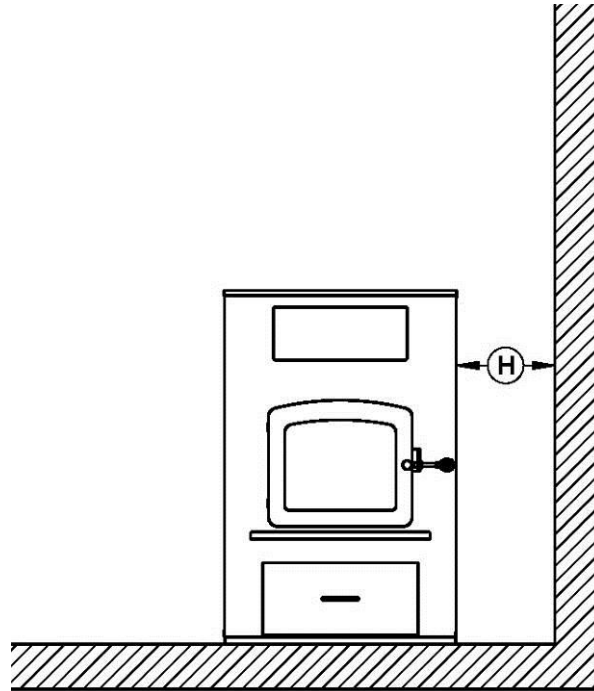

Clearances with a ceiling height (G) of minimum 193 cm

	CLEARANCES (SINGLE WALL PIPE)
A	406 mm
B	457 mm
E	50 mm
F	25 mm
G	193 cm
H	280 mm

	MINIMUM MEASUREMENTS
C	305 mm
D	193 cm

The Tundra furnace's cold air return option can be connected to a new or to an existing cold air return ductwork. In both cases, the minimum clearance to combustibles is 0" (0 mm).

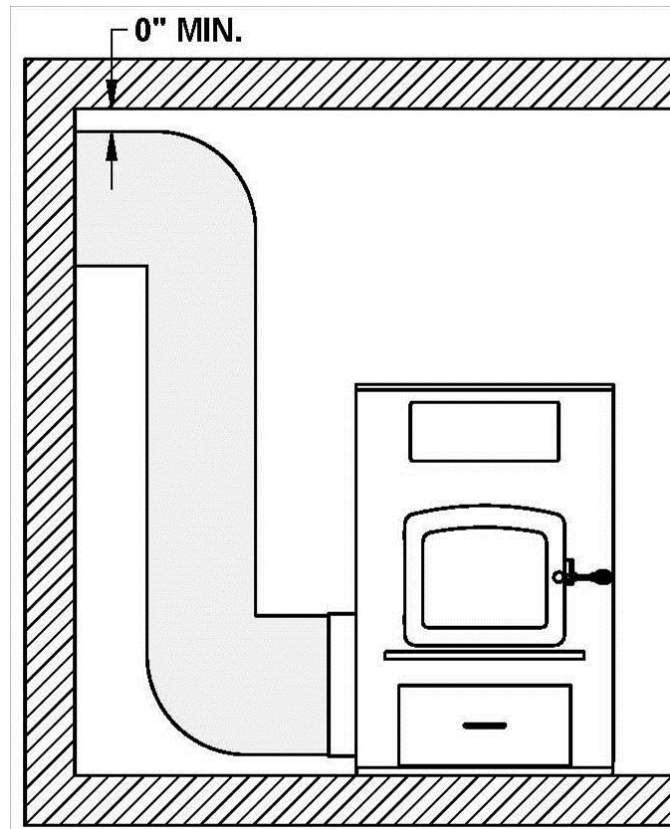

6.3 Floor protector

Your furnace is designed to prevent the floor from overheating. However, it should be placed on a non-combustible surface to protect the floor of the hot embers that might fall from the furnace during loading and maintenance.

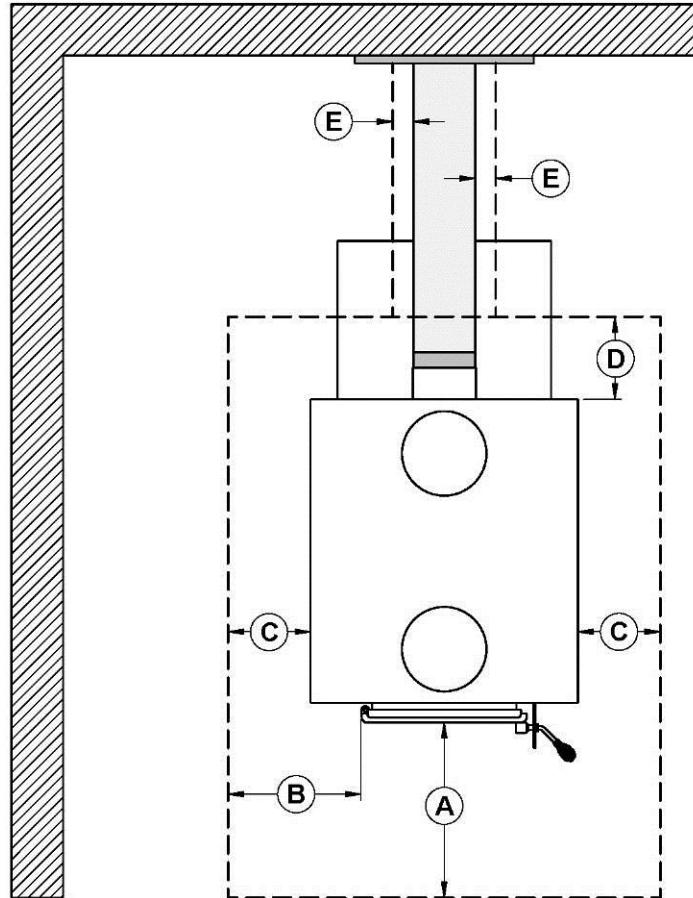

FLOOR PROTECTION*	
A	457 mm (From door opening)
C	203 mm
D	203 mm – Note 1
E	Note 2

**Steel with a minimum thickness of 0.38 mm or ceramic tiles sealed together with grout. No protection is required if the unit is installed on a non-combustible floor (ex: concrete).*

Note 1: The floor protection at the back of the furnace is limited to the furnace's required clearance if such clearance is smaller than 203 mm.

Note 2: Only required under the horizontal section of the flue. Must exceed each side of the flue by at least 51 mm.

6.4 Hot air distribution system

Your Drolet furnace is designed to receive four 204 mm diameter hot air ducts that are located on the top of the cabinet. In the combustion chamber, you will find the necessary adapters to start the air duct system.

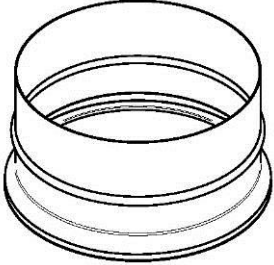
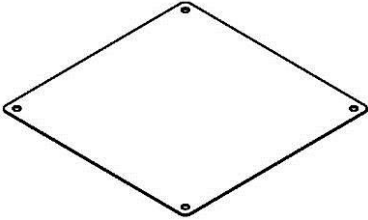
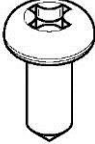
<p>4 hot air start-off adapter (A)</p>	
<p>2 block-off plate (B)</p>	
<p>8 block-off plate screws (C)</p>	

The total run of the hot air ducts should not exceed 15.25 m. To avoid overheating and assure a good hot air distribution, we recommend that the static pressure be set at 50 Pa. Depending on the duct configuration, the setting of the blower speed (factory set at medium low) can be changed to obtain to proper static pressure. Simply change the location of the wire on the terminal.

You can choose from 3 duct outlet configurations. For optimum efficiency and to provide even heat distribution, we recommend the outlet “Configuration **A**”.

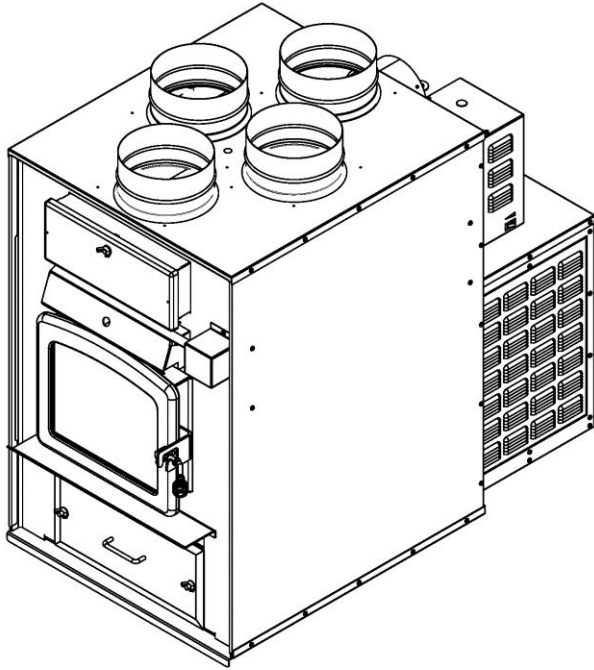

Configuration A (**PREFERRED**)

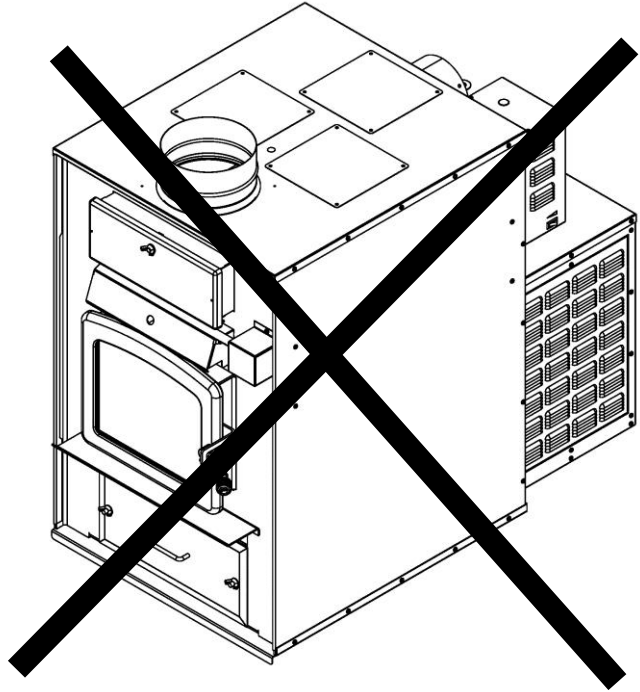

Configuration B (**NOT ALLOWED**)

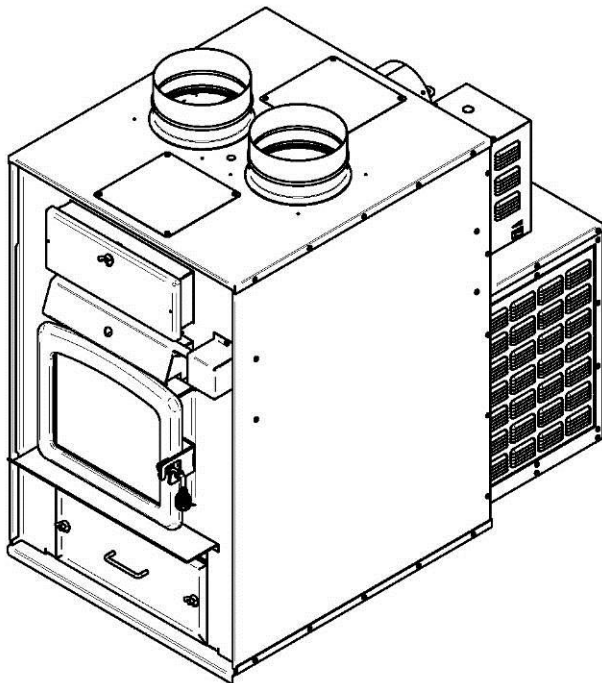

Configuration C (**ACCEPTABLE, NOT RECOMMENDED**)

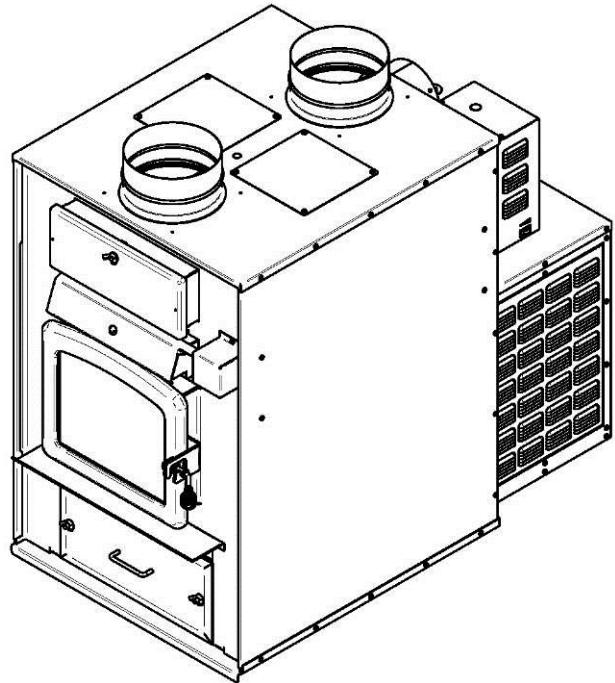

Configuration D (**ACCEPTABLE, NOT RECOMMENDED**)

The first vertical start-off pipe should be no less than 305 mm. The minimum clearance to combustible material of the first 1.83 m horizontal duct run is 52 mm and 26 mm for additional horizontal length. See image in **Section 6.2, Clearances to combustible material.**

Hot air start-off adapter and block-off plate Installation:

Warning: Wear gloves to perform the following steps since edges of adapters and plates may be sharp.

Once the hot air outlet configuration has been chosen, install the start-off adapters and the block-off.

1. Cut a notch in the flange of both adapter **(A)** and slightly fold down one side of the flange to facilitate installation as shown below.

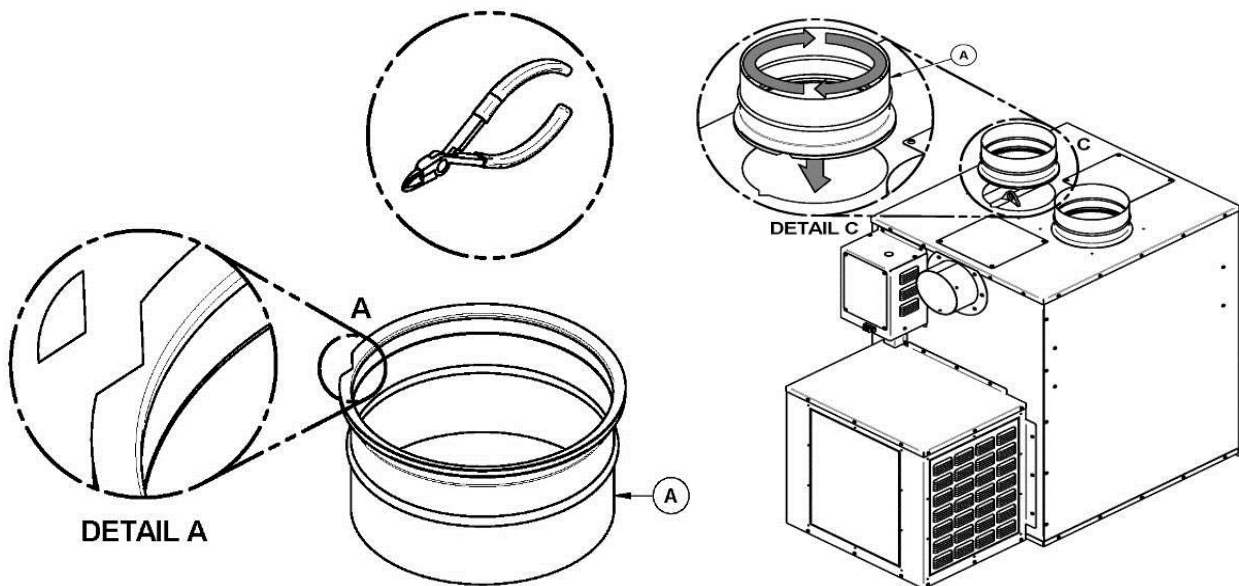

2. Align the notch previously made on the adapter **(A)** with the one of the selected hot air outlet on the top of the furnace. Insert the flange under the furnace top, then turn the adapter until the flange is completely inserted and rotates freely. Repeat the above procedure for the other adapters.
3. Using the provided screws **(C)**, install the block-off plates **(B)** on the remaining hot air outlets if necessary.

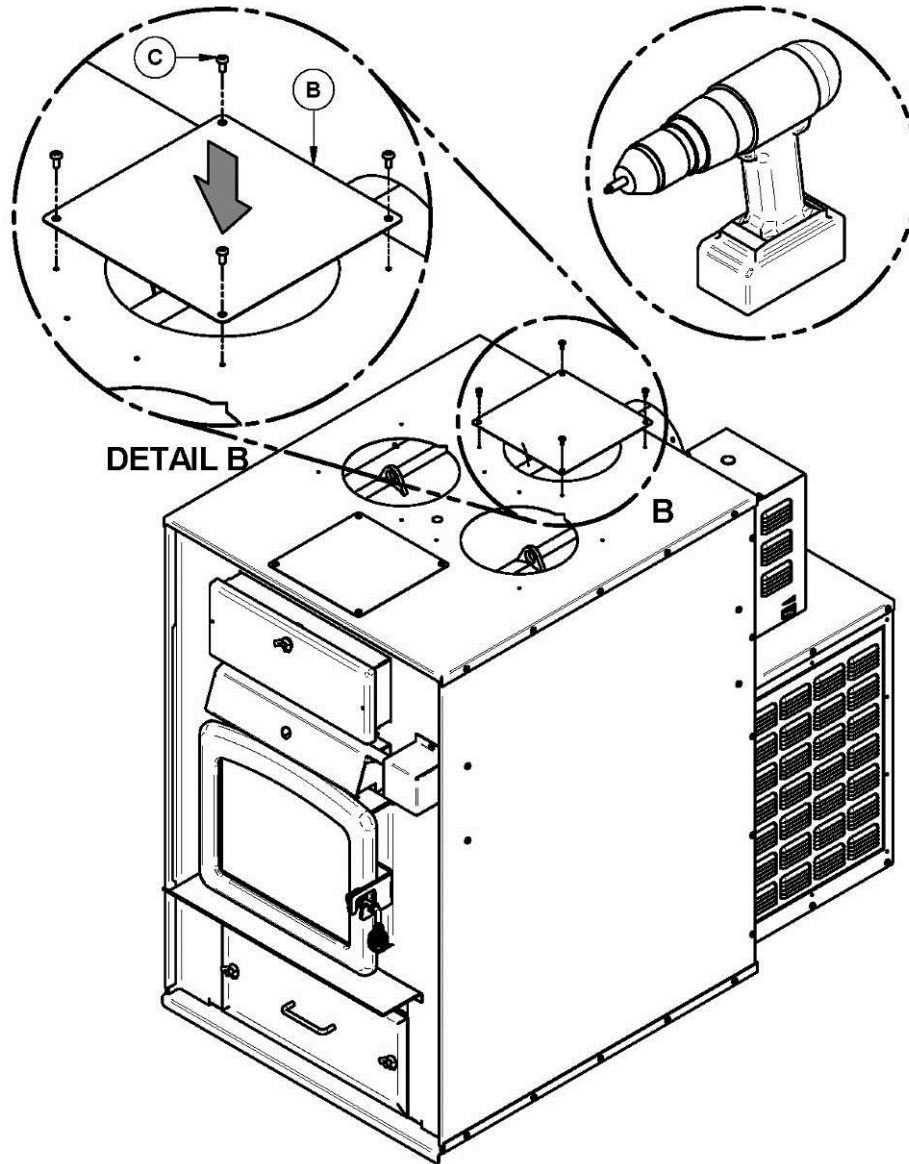

The installation of the air return option connected to the blower housing would improve the air circulation throughout the house (see **Appendix 3: Fresh air return adapter (AC01392)**). The use of the air filter option is also recommended. The filter option will significantly reduce dust circulation within the hot air duct and will prevent obstruction of the blower (see **Appendix 2: Optional filter (AC01390)**).

The installer is responsible of the performance of the distribution ducts and the air return system. It will have a direct effect on the ability of the blower to distribute heat efficiently throughout the house. The number, size and length of the ducts of the distribution system and return air will vary depending on the configuration and characteristics of each house.

N.B.: The furnace air jacket is not totally air tight. It is normal to detect some air leaks at the jacket's joints.

6.4.1 Authorized configurations

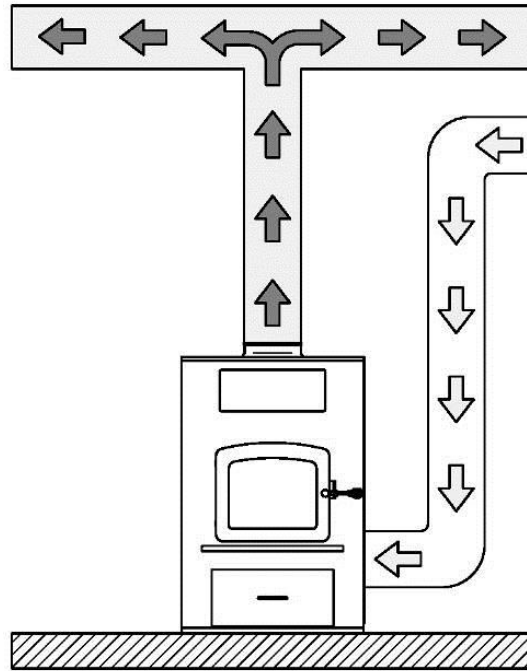

The installation of this furnace in parallel with another furnace that uses the same system of hot air ducts are allowed. Ideally, the maximum input of the existing gas, oil or electric furnace should be equal to or higher than the wood furnace. It is mandatory to meet the minimum clearances between the hot air ducts and combustible materials like the wood furnace was installed alone. Necessary adjustments should be made to the furnace or hot air ducts to maintain a static pressure 50 Pa. To prevent a return air in either of the two furnaces, a non-return ('back flow damper') damper must be installed. The non-return damper is necessary to ensure that the hot air flow through the house and does not return through the plenum of the other furnace. Depending on your installation (see examples below), a damper may be installed in each plenum.

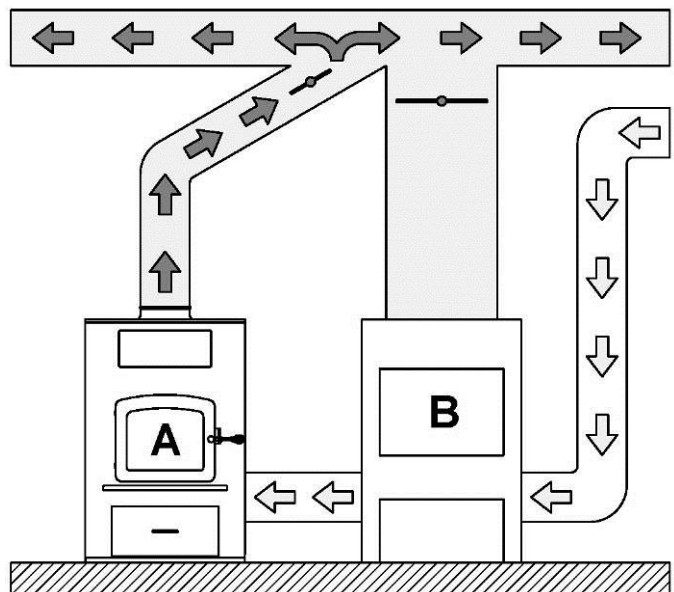

6.4.2 Non-authorized configuration

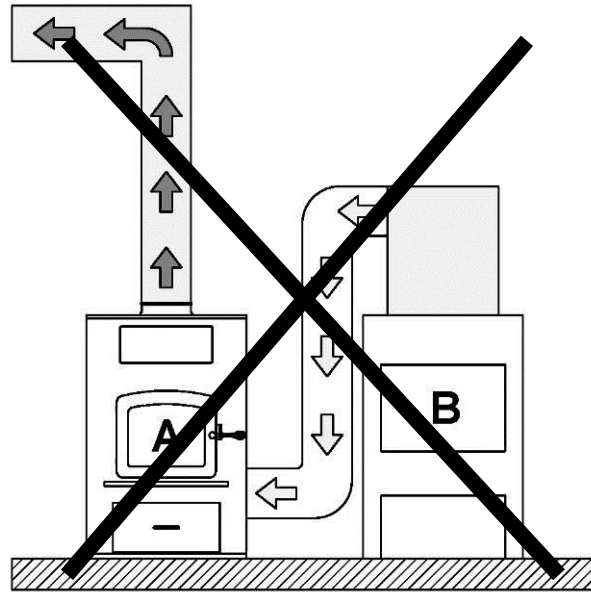

7 The venting system

7.1 General

The venting system, made up of the flue system and the connecting pipe between the furnace and the flue system, acts as the engine that drives your wood heating system. Even the best furnace will not function safely and efficiently as intended if it is not connected to a suitable flue system.

The heat in the flue gases that pass from the furnace and flue system connector into the flue system is not waste heat. This heat is what the flue system uses to make the draft that draws in combustion air, keeps smoke inside the furnace and safely vents exhaust to outside. You can think of heat in the flue gas as the fuel the flue system uses to make draft.

7.2 Suitable flue systems

Your wood furnace will provide optimum efficiency and performance when connected to a 152 mm diameter flue system flue system. The connection to a flue system having a diameter of at least 125 mm or no more than 180 mm is permitted, if it allows the proper venting of combustion gases and that such application is verified and authorized by a qualified installer. Otherwise, the diameter of the flue should be 152 mm.

7.2.1 Factory-built metal flue systems

These are sometimes referred to as 'high temp' chimneys because they have the special characteristics to withstand the temperatures that can be created by wood burning stoves. Factory-built chimneys are tested as a system with all the necessary components for installation. The instructions provided with the chimney by its manufacturer are the only reliable source of installation guidelines. To be safe and effective, the chimney must be installed exactly in accordance with the manufacturer's instructions. **Use only components intended for the brand and model of chimney you are using. Never substitute parts from other chimney brands or fabricate your own components. The chimney must be a type suitable for solid fuel.**

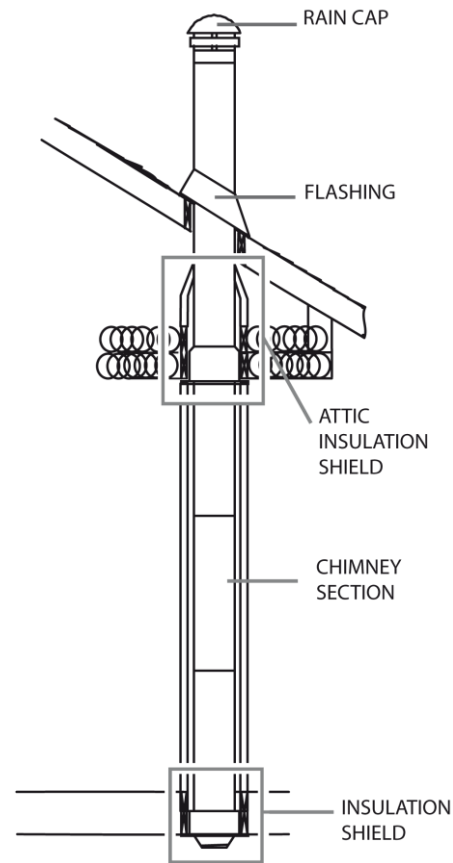

7.2.2 Masonry flue systems

The stove may also be connected to a masonry chimney, provided the chimney complies with the construction rules found in the building code enforced locally. The chimney must have either a clay liner or a suitably listed stainless steel liner. If the masonry chimney has a square or rectangular liner that is larger in cross sectional area than a round 150 mm flue, it should be relined with a 150 mm stainless steel liner. Do not downsize the flue to less than 150 mm unless the venting system is straight and exceeds 7.62 m in height. When passing through a combustible wall, the use of an insulated thimble is required.

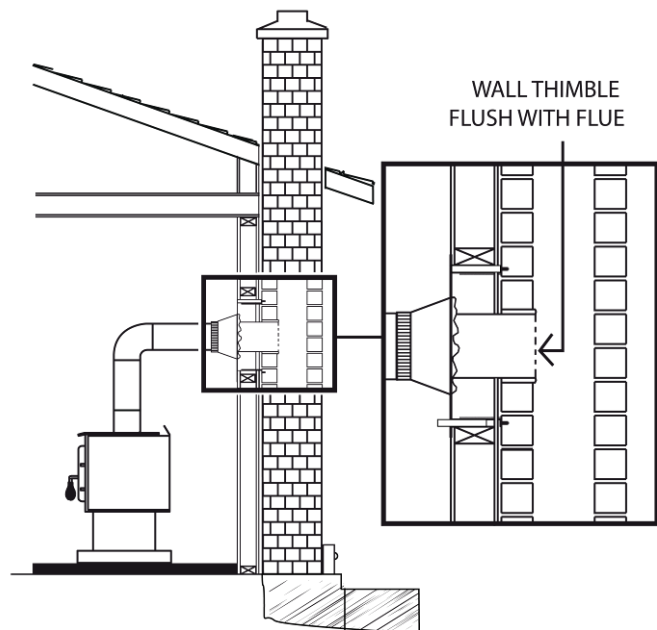

7.3 Air supply in conventional houses

The safest and most reliable supply of combustion air for your wood furnace is from the room in which it is installed. Room air is already preheated so it will not chill the fire, and its availability is not affected by wind pressures on the house. Contrary to commonly expressed concerns, almost all tightly-sealed new houses have enough natural leakage to provide the small amount of air needed by the furnace. The only case in which the wood furnace may not have adequate access to combustion air is if the operation of a powerful exhaust device (such as a kitchen range exhaust) causes the pressure in the house to become negative relative to outdoors.

If you do install an air supply through the wall of the house, be aware that its pressure can be affected during windy weather. If you notice changes in wood furnace performance in windy weather, and in particular if smoke puffs from the furnace, you should disconnect the outdoor air duct from the furnace and remove the duct. In some windy conditions, negative pressure at the duct weatherhood outside the house wall may draw hot exhaust gases from the furnace backwards through the duct to outdoors. Check the outdoor air duct for soot deposits when the full system is cleaned and inspected at least once each year.

8 Electrical connections and controls

The TUNDRA furnace is fully assembled at the factory and no electrical connection is required other than plugging the power cord into an outlet.

8.1 Wiring diagram

The following instructions do not replace those of the local code.

Installation and verification of this appliance must be done by a qualified service man.

All wiring from the service panel to the heating unit must comply with the electrical code in force and all local regulations. It is recommended to feed the furnace with its own electrical circuit (see wiring diagram).

<p style="text-align: center;"><u>WARNING</u> ONLY USE WIRES SUITABLE FOR 75 °C OR MORE.</p>
--

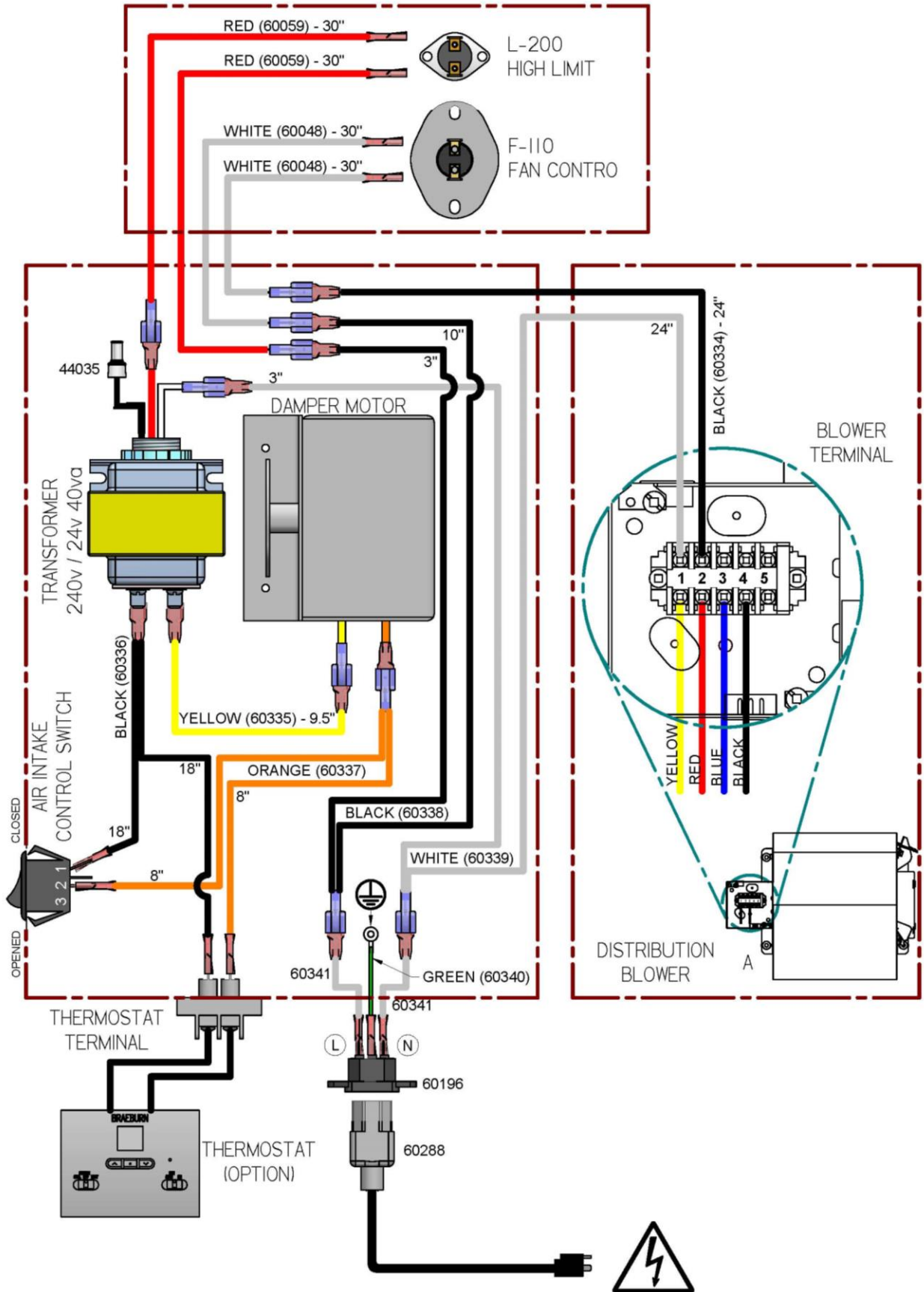

8.2 Manual or thermostat control

From factory, the opening and closing of the air inlet damper is manually activated by the means of a switch located at the rear of the furnace. The switch has two positions; opened and closed.

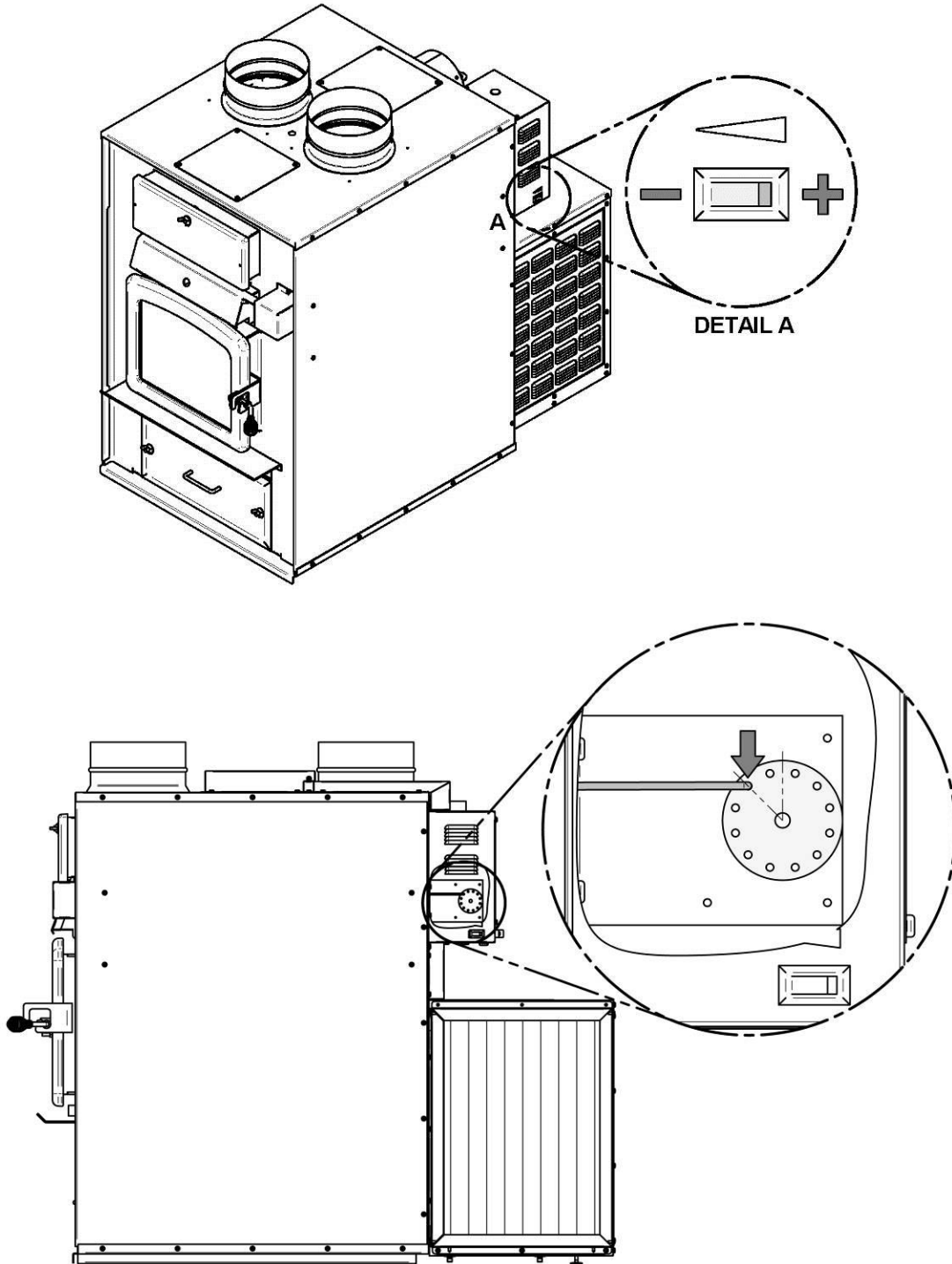

Position of the air control rod when the switch in the “closed” position.

For added comfort, the installation of an optional wall thermostat is recommended since it will open the air inlet damper when the room temperature is below the set point of the thermostat and will close the air inlet damper as the desired temperature is reached (see **Appendix 1: *Optional Thermostat Installation***).

If the heat sensors detect any overheating in the air jacket of the furnace, the air inlet damper will close automatically regardless of the type of control used.

8.3 Blower control

The blower is activated when the air jacket temperature of the furnace reaches 60 °C and stops when it drops below 49 °C. If the air jacket temperature exceeds 71 °C, the air inlet damper closes and the blower will continue to blow until temperature returns below 49 °C at which point the air inlet control will open again.

To optimize the heat distribution efficiency of the furnace, the blower of the TUNDRA was set at the factory on speed 1 (low). If needed, it is possible to change the blower speed by moving the black wire coming from the control box to the desired speed (see electrical diagram). Make sure the new setting complies with the recommendations of the National Association of Hot Air Heating and Air Conditioning while respecting the recommended static pressure.

Flow as function of blower speed

Blower speed	Static pressure (Pa)	Flow (CFM)
1	50	1,000
2	50	1,200
3	50	1,400

Appendix 1: Optional thermostat installation

Using a thermostat will help you maintain a constant temperature throughout the house. A fixed wall mounted 24v thermostat is required.

Note: Thermostat manufacturer's instruction always overrides the information published in this section.

Thermostat location

The thermostat must be installed on an inside wall of the house and where it will be the least affected by air currents from a hot air outlet or cold outside walls. The thermostat must be installed at a minimum of 1.4 m above the floor.

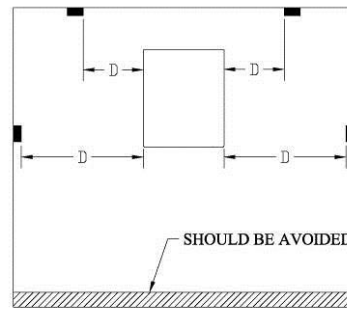

D = MINIMUM DISTANCE 15 FEET

Thermostat wiring

Before installing the thermostat, disconnect the furnace from the outlet. Use a 18 AWG 2 strand wire. Connect the two wires from the thermostat to the terminal at the rear right side of the furnace. To do this, loosen the two screws in the middle of the terminal bloc and insert the wires in the terminals. Tighten the two screws. Then open the thermostat housing and connect the wires following the manufacturer's instructions.

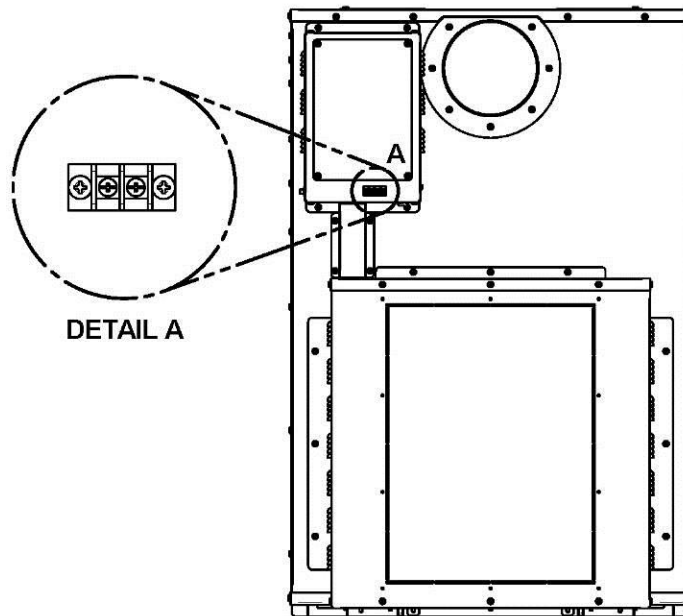

Exemple of thermostat wiring

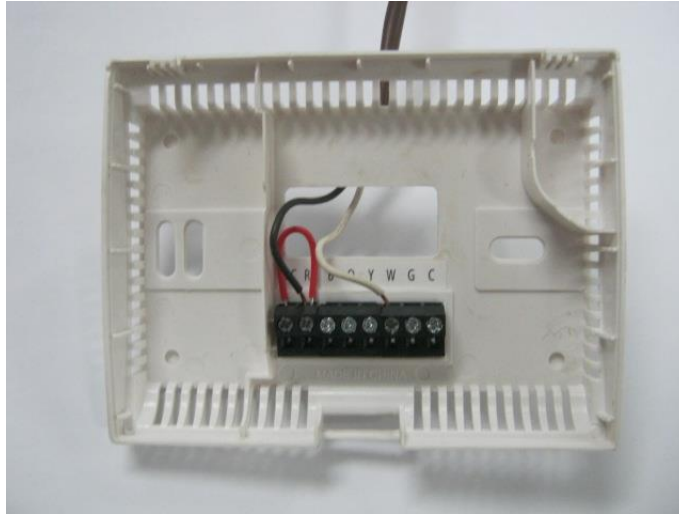

Connect one wire to "RH" and the other wire to "W". The red jumper can be left in place. For more information, refer to the manufacturer's instructions.

Use in thermostat mode

To ensure proper operation of the air inlet damper while connected to a thermostat, the manual control switch must be maintained in the closed position. However, when a thermostat is connected to the furnace, it is still possible to use the manual control switch to open the air damper if desired. Even though you chose to control the furnace with a thermostat it is still possible to use the manual control switch to open the air intake damper if desired.

Appendix 2: Optional filter (AC01390)

The filter option (part number AC01390) allows filtering dirt before distribution warm air in your installation in addition of protecting your blower. This system can be installed on any side of the blower box located behind the furnace on the most accessible side of your installation. This option includes the filter, the filter holder, two caps and the screws necessary for the installation.

Clean and replace filters as often as required.

Note: The operation cost is higher when using a dirty filter.

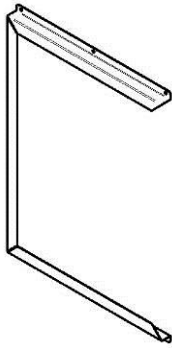

1 filter holder

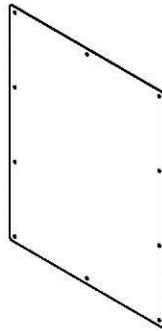

2 caps

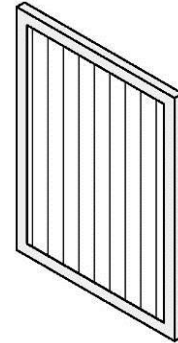

1 filter (381 mm x 508 mm x 25 mm)

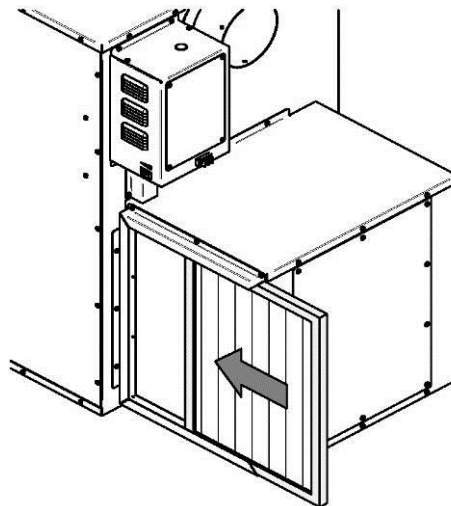

WARNING: IT IS NOT RECOMMENDED TO OPERATE THE FURNACE WITHOUT FILTERS. THIS APPLIES ESPECIALLY TO TEMPORARY HEATING DURING CONSTRUCTION PERIOD. OPERATING THE FURNACE WITHOUT FILTERS WOULD ALLOW DUST AND OTHER PARTICLES IN THE AIR TO CIRCULATE FREELY AND TO PENETRATE INTO THE BLOWER AND MOTOR CARTERS, CAUSING SOME DEFECTS.

Appendix 3: Optional Fresh air return adapter (AC01392)

The optional air return adapter (AC01392) can be added to the furnace blower box to increase the efficiency of your system. This option allows you to take in the fresh air from the rooms connected to the return system and bring it back towards the furnace to be heated. This option can be installed on either one of the 3 sides of the blower box. Complete installation instruction can be found in the instruction booklet provided when purchasing this option.

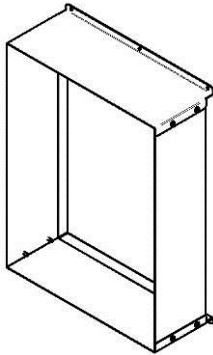

1 fresh air return adapter

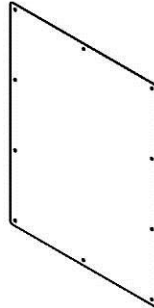

2 caps

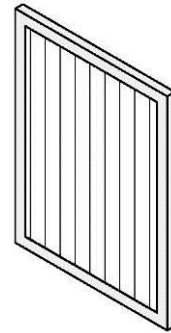

1 filter

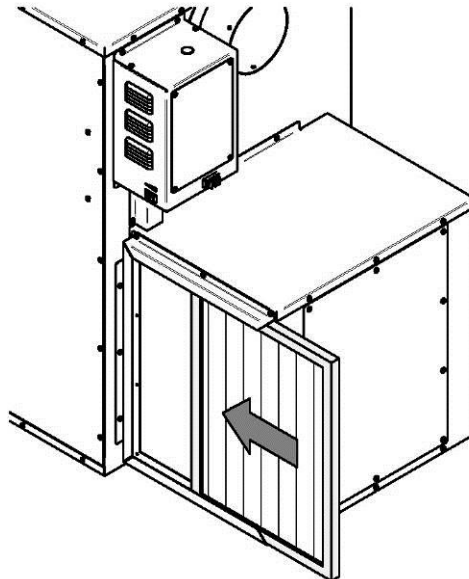

N.B.: TO ENSURE ADEQUATE STATIC PRESSURE, THE SYSTEM SHOULD BE BUILT IN A WAY THAT THE VOLUME OF COLD AIR RETURN IS AT LEAST EQUAL OR SLIGHTLY HIGHER THAN THE VOLUME OF THE HOT AIR DISTRIBUTION.

Appendix 4: Installation of secondary air tubes and baffle

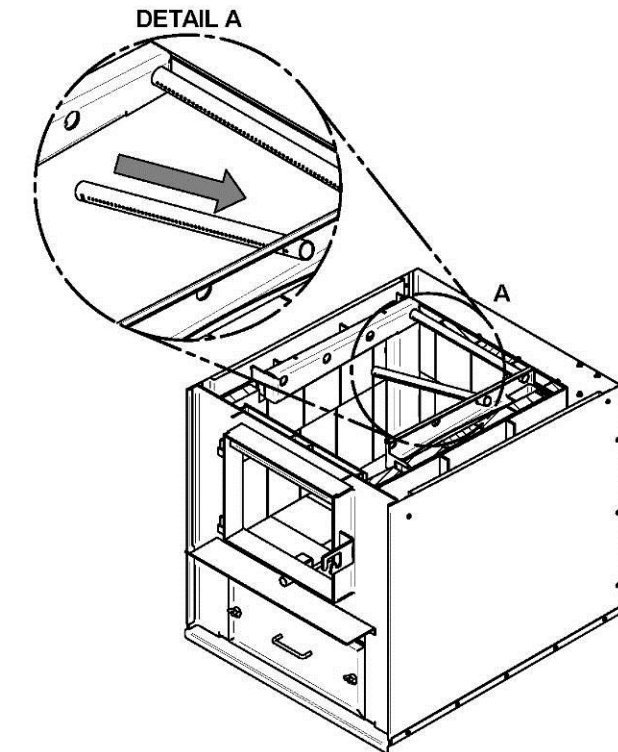

- 1- Starting with the rear tube, lean and insert the right end of the secondary air tube into the rear right channel hole. Then lift and insert the left end of the tube into the rear left channel.

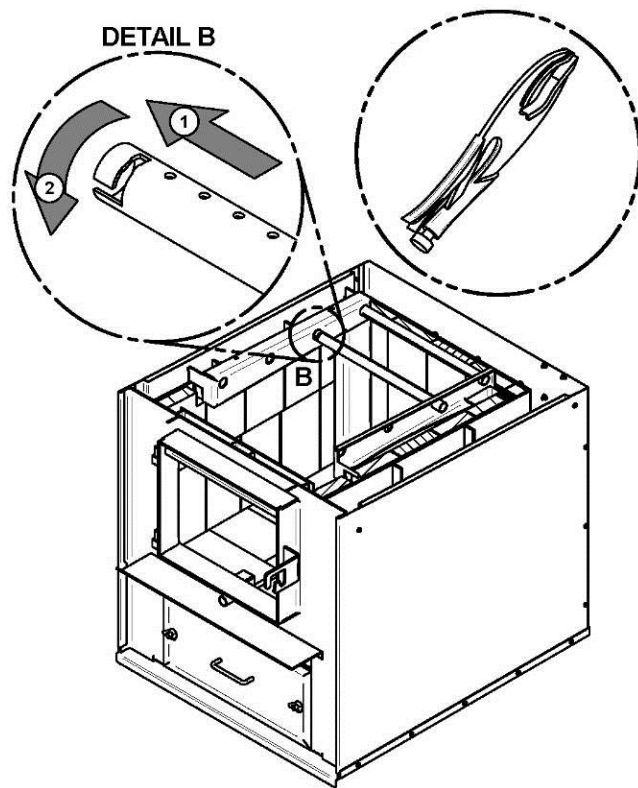

- 2- Align the notch in the left end of the tube with the key of the left air channel hole. Using a « Vise grip » pliers hold the tube and lock it in place by turning the tube as shown in **Detail A**. Make sure the notch reaches the end of the key way.
- 3- Repeat **step 1** and **2** for the other secondary air tubes.
- 4- To remove the tubes use the above steps in reverse order.

Note that secondary air tubes (A) can be replaced without removing the baffle board (B).

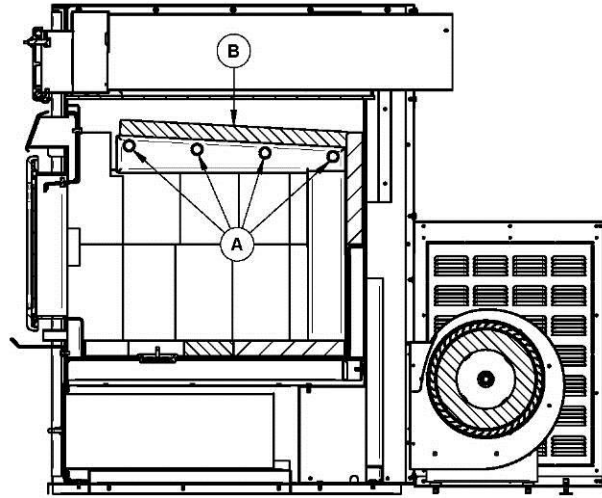

Important Notes:

The air tubes are identified for placement as follows:

Model	Type of tube
TUNDRA	Front ► 106 holes of 2.769 mm Middle front ► 53 holes of 2.769 mm Middle rear ► 53 holes of 2.769 mm Rear ► 53 holes of 2.769 mm

Appendix 5: Troubleshooting

PROBLEM	CAUSES	SOLUTIONS
Heating inefficient during the first combustions. Lack of draft.	Improper adjustment of the barometric damper (opened too wide). Flue system flue restriction (too long, 90° elbows)	Adjust the damper, minimize the smoke pipe length and use 45° elbows.
Furnace burns well, warm air plenum is very hot but there is not much heat coming out in the room.	Improper installation of the ducts, low static pressure, unbalanced system (too many warm air outlets and not enough cold air inlets).	Rearrange the ducting to respect the minimum static pressure of 50 Pa.
Furnace consumes a lot of wood.	Damper switch left always on. The thermostat which controls the damper is continuously activated or is too close to a source of cold air. Damper not properly adjusted. House not insulated enough. Ash plug and drawer are not tightly closed. Furnace too small for the surface to be heated. Unbalanced ventilation system, very little heat where the thermostat is located.	If manually controlled, install a wall thermostat. Relocate the thermostat. Rebalance the ventilation system in order to increase the air flow in the room where the thermostat is located.
A lot of creosote, moderate heat output.	Wet wood, lack of draft. Barometric damper not properly adjusted. Restriction in the furnace or flue system.	Use dry wood. Adjust the barometric damper. Clean the flue system, flue pipe and the furnace exchangers.
Furnace heats a lot but the warm air duct does not get hot.	Wet wood or low grade wood. No static pressure. Unbalanced ventilation system.	Use dry wood. Rearrange the ventilation system correctly.
Primary air inlet damper never opens.	Furnace is not plugged-in or an electrical component is faulty.	Make sure the furnace is plugged-in a functional power outlet. Test and replace if necessary, control switch, thermostat, themodisc and damper motor.

IMPORTANT NOTE

FOR, INSTALLATION OF A CENTRAL HEATING VENTILATION SYSTEM, IT IS HIGHLY RECOMMENDED TO CONSULT A HEATING SYSTEM VENTILATION SPECIALIST.

N.B.: STOVE BUILDER INTERNATIONAL INC. IS NOT RESPONSIBLE FOR POOR APPLIANCE PERFORMANCES, DUE TO IMPROPER INSTALLATION OF EXHAUST SYSTEM OR DUCTING.

Appendix 6: Exploded diagram and parts list

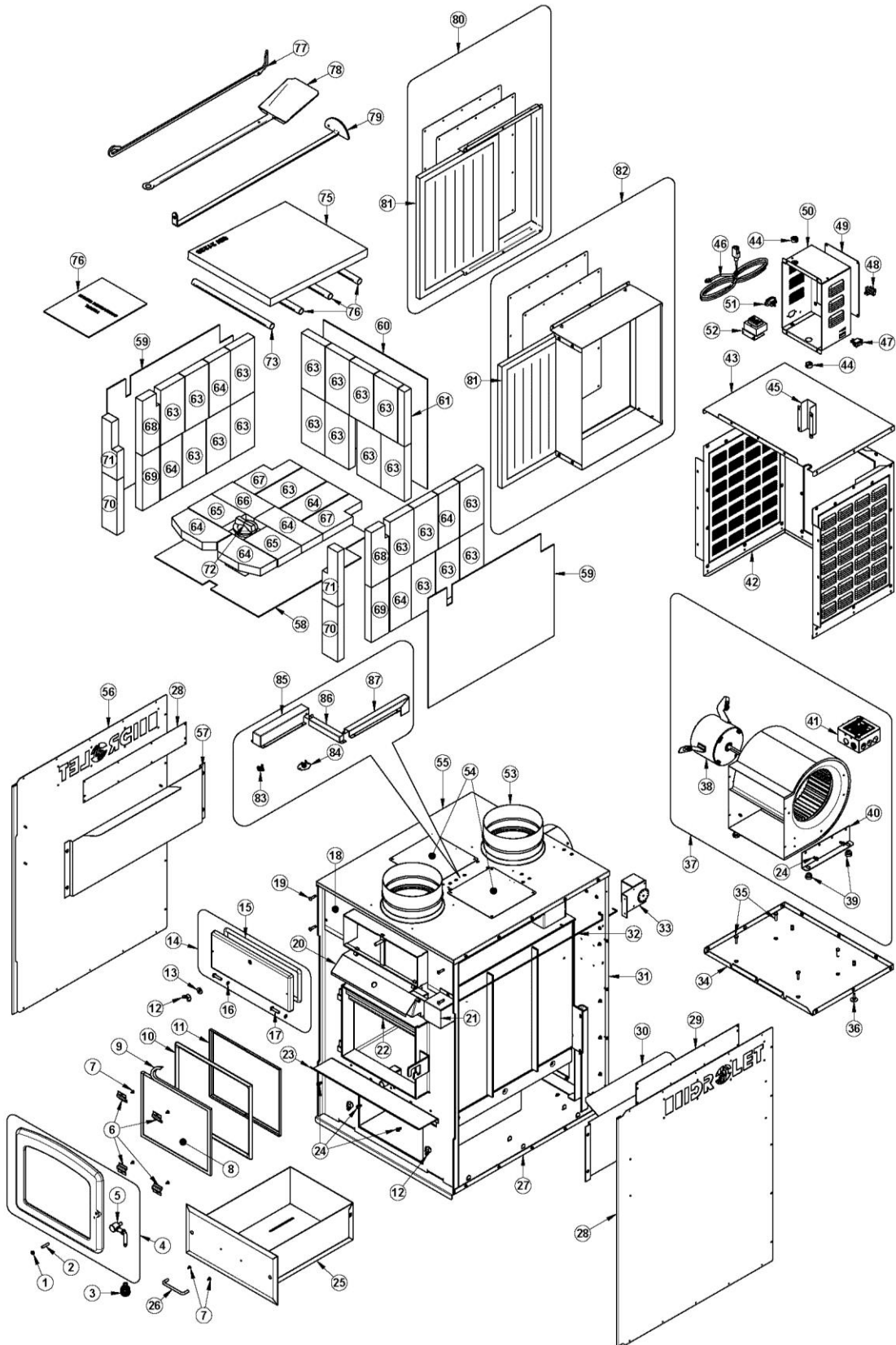

IMPORTANT: THIS IS DATED INFORMATION. When requesting service or replacement parts for your furnace, please provide the model and the serial number. We reserve the right to change parts due to technology upgrade or availability. Contact an authorized dealer to obtain any of these parts. Never use substitute materials. Use of non-approved parts can result in poor performance and safety hazards.

#	Item	Description	Qty
1	30100	BLACK HEX NUT 1/4 - 20	1
2	30128	SOCKET SET SCREW 1/4"-20 X 1 1/4"	1
3	30429	3/8" NICKEL COIL HANDLE	1
4	SE24258	CAST IRON DOOR WITH HANDLE	1
5	AC09151	REPLACEMENT HANDLE KIT	1
6	PL51351	GLASS RETAINER FRAME BRACKET	4
7	30124	SCREW #8 - 32 X 5/16" TRUSS QUADREX ZINC	6
8	SE51352	REPLACEMENT GLASS WITH GASKET 10 7/8" X 13 1/8"	1
9	AC06400	6' BLACK SELF-ADHESIVE GLASS GASKET	1
10	AC06725	GLUE AND 3/4" X 7' WHITE DOOR GASKET KIT	1
11	PL51349	GLASS RETAINER FRAME	2
12	30416	WING NUT 3/8"-16	1
13	30210	WASHER 29/32" OD X 3/8" ID ZINC	1
14	SE48054	HEAT EXCHANGER ACCESS DOOR	1
15	AC06000	SILICONE AND 1/2" X 8' BLACK DOOR GASKET REPLACEMENT KIT	1
16	30055	HINGE PIN RETAINING RING 5/16" ID X 0.512" OD	2
17	30168	HINGE PIN 5/16 DIA. X 1 1/4" LONG	2
18	PL66038	FACEPLATE UPPER OVERLAP	1
19	30506	SCREW PAN TORX TYPE F 1/4-20 X 1" BLACK	4
20	PL66021	PRIMARY AIR INLET DAMPER	1
21	PL66058	AIR INLET DAMPER PROTECTION BOX	1
22	PL66012	PRIMARY AIR DEFLECTOR HEAT SHIELD	1
23	PL56276	ASH SHELF	1
24	30060	THREAD-CUTTING SCREW 1/4-20 x 1/2" F HEX STEEL SLOT WASHER C102 ZINC	7
25	SE66025	ASH DRAWER	1
26	28061	CHROME ASH DRAWER HANDLE	1
27	SE66009	AIR JACKET FLOOR ASSEMBLY	1
28	PL66032	RIGHT AIR JACKET PANNEL	2
29	PL66052	RIGHT AIR JACKET PANNEL BACKING PLATE	2
30	PL66019	RIGHT CONVECTION AIR DEFLECTOR	1
31	PL66033	FURNACE BACK	1
32	PL66068	PRIMARY AIR CONTROL ROD	1
33	SE51000	HONEYWELL 24V DAMPER MOTOR WITH TERMINALS	1
34	PL66035	BLOWER BOX BASE	1
35	30109	BOLT HEX 1/4"-20 X 1"	4

#	Item	Description	Qty
36	30536	LEVELING BOLT 1/4"-20 x 1"	2
37	SE66038	BLOWER ASSEMBLY WITH 1/4 HP MOTOR, DD 4 SPEED 1075/4RPM	2
38	51052	1/4 HP DD-4 SPEED MOTOR 1075/4RPM	1
39	30335	BLOWER ANTI-VIBRATION CUSHION	4
40	PL66037	BLOWER HOUSING BASKET	2
41	44006	ELECTRICAL BOX 4" X 4" X 2 1/8"	1
42	PL66043	BLOWER BOX SURROUND	1
43	PL66042	BLOWER BOX TOP	1
44	30412	BLACK UNIVERSAL SNAP-IN BUSHING	2
45	PL66041	WIRE CHANNEL	1
46	60288	POWER CORD	1
47	44091	ROCKER SWITCH 2 POSITION MSR-8	1
48	60036	THERMOSTAT TERMINAL	1
49	PL66080	CONTROL HOUSING COVER	1
50	PL66067	CONTROL HOUSING	1
51	60196	POWER CORD RECEPTACLE	1
52	60244	TRANSFORMER 240 V/24 V 40 VA	1
53	49438	8" (203MM) DIAMETER START-OFF ADAPTER	4
54	PL66039	BLOCK-OFF PLATE	2
55	PL66034	TOP AIR JACKET	1
56	PL66031	LEFT AIR JACKET PANNEL	1
57	PL66063	LEFT CONVECTION AIR DEFLECTOR	1
58	21299	FIREBOX BOTTOM INSULATION	2
59	21084	FIREBOX SIDE INSULATION	2
60	21083	FIREBOX BACK INSULATION	1
61	PL36162	1 1/4" X 9" REFRACTORY BRICK	1
62	PL36248	REFRACTORY BRICK 4 1/2" X 8 5/16" X 1 3/8" X 1 3/8"	2
63	29020	4 1/2" X 9" X 1.25" REFRACTORY BRICK	21
64	29011	4" x 9" x 1.25" REFRACTORY BRICK	6
65	PL36047	4 1/2" X 6 1/2" X 1 1/4" REFRACTORY BRICK	2
66	29001	4" X 8" X 1.25" REFRACTORY BRICK	1
67	PL36163	4" X 9" X 1 5/8" X 3 5/16" REFRACTORY BRICK	2
68	PL36249	REFRACTORY BRICK 3 1/2" X 9" X 5/8" X 2 1/8"	2
69	PL36102	REFRACTORY BRICK 3 1/4" X 9"	2
70	PL36255	REFRACTORY BRICK 2 7/8" X 9" X 1 1/4"	2
71	PL36254	REFRACTORY BRICK 2 7/8" X 9" X 1" X 4 3/8"	2
72	SE16059	ASH DUMP PLUG	1
73	PL66062	FRONT SECONDARY AIR TUBE	1
74	PL66061	SECONDARY AIR TUBE	3
75	21228	C-CAST BAFFLE 18 3/8" X 15 1/2" X 1 1/4"	1

#	Item	Description	Qty
76	SE45656	TUNDRA FURNACE INSTRUCTION MANUAL KIT	1
77	PL48173	POKER	1
78	PL48171	ASH SHOVEL	1
79	PL48170	HEAT EXCHANGER SCRAPER	1
80	AC01390	CARDBOARD FRAME AIR FILTER WITH SUPPORT	1
81	21044	CARDBOARD AIR FILTER 20" X 15" X 1"	2
82	AC01392	COLD AIR RETURN HOUSING WITH FILTER	1
83	44060	THERMODISC 36T11 L200 AUTOMATIC	1
84	44028	CERAMIC THERMODISC F110-20F	1
85	PL66093	THERMAL SWITCH HOUSING	1
86	PL66094	MIDDLE WIRE PROTECTOR	1
87	PL66095	REAR WIRE PROTECTOR	1

DROLET LIMITED WARRANTY

The warranty of the manufacturer extends only to the original consumer purchaser and is not transferable. This warranty covers brand new products only, which have not been altered, modified nor repaired since shipment from factory. Proof of purchase (dated bill of sale), model name and serial number must be supplied when making any warranty claim to your DROLET dealer.

This warranty applies to normal residential use only. Damages caused by misuse, abuse, improper installation, lack of maintenance, over firing, negligence or accident during transportation, power failures, downdrafts, or venting problems are not covered by this warranty.

This warranty does not cover any scratch, corrosion, distortion, or discoloration. Any defect or damage caused by the use of unauthorized parts or others than original parts void this warranty. An authorized qualified technician must perform the installation in accordance with the instructions supplied with this product and all local and national building codes. Any service call related to an improper installation is not covered by this warranty.

The manufacturer may require that defective products be returned or that digital pictures be provided to support the claim. Returned products are to be shipped prepaid to the manufacturer for investigation. If a product is found to be defective, the manufacturer will repair or replace such defect. Transportation fees to ship the product back to the purchaser will be paid by the manufacturer. Repair work covered by the warranty, executed at the purchaser’s domicile by an authorized qualified technician requires the prior approval of the manufacturer. Labour cost and repair work to the account of the manufacturer are based on predetermined rate schedule and must not exceed the wholesale price of the replacement part. All parts and labour costs covered by this warranty are limited according to the table below.

The manufacturer at its discretion may decide to repair or replace any part or unit after inspection and investigation of the defect. The manufacturer may, at its discretion, fully discharge all obligations with respect to this warranty by refunding the wholesale price of any warranted but defective parts. The manufacturer shall in no event be responsible for any special, indirect, consequential damages of any nature, which are in excess of the original purchase price of the product. A one-time replacement limit applies to all parts benefiting from a lifetime coverage. This warranty applies to products purchased after October 1st, 2011.

DESCRIPTION	WARRANTY APPLICATION	
	PARTS	LABOUR
Combustion chamber (welds only), castings, convector air-mate, ceramic glass (thermal breakage only*).	20 years	5 years
Plating* (defective manufacture) – subject to limitations above.	20 years	n/a
Stainless steel firebox components, surrounds and heat shields, ash drawer, steel legs, pedestal, trims (aluminum extrusions), secondary air tubes*, C-Cast baffle*, and vermiculite baffle*.	7 years	3 years
Carbon steel firebox components, glass retainers, and handle assembly.	5 years	3 years
Blowers, heat sensors, switches, rheostat, wiring, and other controls.	2 years	1 year
Paint (peeling), gaskets, insulation, firebrick, and ceramic fibre blankets.	1 year	n/a

**Pictures required*

Shall your unit or a components be defective, contact immediately your DROLET dealer. Prior to your call make sure you have the following information necessary to your warranty claim treatment:

- Your name, address and telephone number;
- Bill of sale and dealer’s name;
- Serial number and model name as indicated on the nameplate fixed to the back of your unit;
- Nature of the defect and any relevant information.

Before shipping your unit or defective component to our plant, you must obtain from your DROLET dealer an Authorization Number. Any merchandise shipped to our plant without authorization will be refused automatically and returned to sender.